

# EXHIBIT 2



US009841174B2

(12) **United States Patent**  
**Liu et al.**

(10) **Patent No.:** **US 9,841,174 B2**  
(45) **Date of Patent:** **Dec. 12, 2017**

(54) **LED TUBE LAMP**

(71) Applicant: **JIAXING SUPER LIGHTING ELECTRIC APPLIANCE CO., LTD.**, Jiaxing (CN)

(72) Inventors: **Xintong Liu**, Jiaxing (CN); **Aiming Xiong**, Jiaxing (CN); **Tao Jiang**, Jiaxing (CN)

(73) Assignee: **Jiaxing Super Lighting Electric Appliance Co., Ltd.**, Jiaxing, Zhejiang (CN)

(\* ) Notice: Subject to any disclaimer, the term of this patent is extended or adjusted under 35 U.S.C. 154(b) by 0 days.

(21) Appl. No.: **15/426,785**

(22) Filed: **Feb. 7, 2017**

(65) **Prior Publication Data**

US 2017/0159923 A1 Jun. 8, 2017

**Related U.S. Application Data**

(63) Continuation of application No. 15/210,989, filed on Jul. 15, 2016, now Pat. No. 9,587,817, which is a (Continued)

(30) **Foreign Application Priority Data**

Aug. 26, 2015 (CN) ..... 2015 1 0530110  
 Sep. 6, 2015 (CN) ..... 2015 1 0557717

(Continued)

(51) **Int. Cl.**  
**H05B 37/00** (2006.01)  
**H05B 41/00** (2006.01)

(Continued)

(52) **U.S. Cl.**  
 CPC ..... **F21V 25/02** (2013.01); **F21K 9/272** (2016.08); **F21K 9/278** (2016.08); **F21V 3/02** (2013.01);

(Continued)

(58) **Field of Classification Search**  
 CPC ..... F21Y 2103/10; F21Y 2115/10  
 See application file for complete search history.

(56) **References Cited**

**U.S. PATENT DOCUMENTS**

5,936,599 A 8/1999 Reymond  
 7,380,961 B2 6/2008 Moriyama

(Continued)

**FOREIGN PATENT DOCUMENTS**

CN 200965185 10/2007  
 CN 101715265 5/2010

(Continued)

*Primary Examiner* — Anh Tran

(74) *Attorney, Agent, or Firm* — Muir Patent Law, PLLC

(57) **ABSTRACT**

An LED tube lamp is provided herein, which implements the safety function for protecting the user from electric shock since it conducts only when both ends thereof have been correctly installed into a lamp socket. The LED tube lamp includes a lamp tube; two end caps, each having an external connection terminal, and each coupled to a respective end of the lamp tube, wherein the external connection terminals are configured to receive an external driving signal; an LED module, configured to emit light based on the external driving signal; and an installation detection module, coupled on a power loop of the LED tube lamp and configured to detect a sampling signal on the power loop and compare the sampling signal with a predefined signal, wherein when a signal level of the sampling signal is smaller than the predefined signal, the installation detection module limits a current on the power loop less than 5 MIU.

**32 Claims, 16 Drawing Sheets**

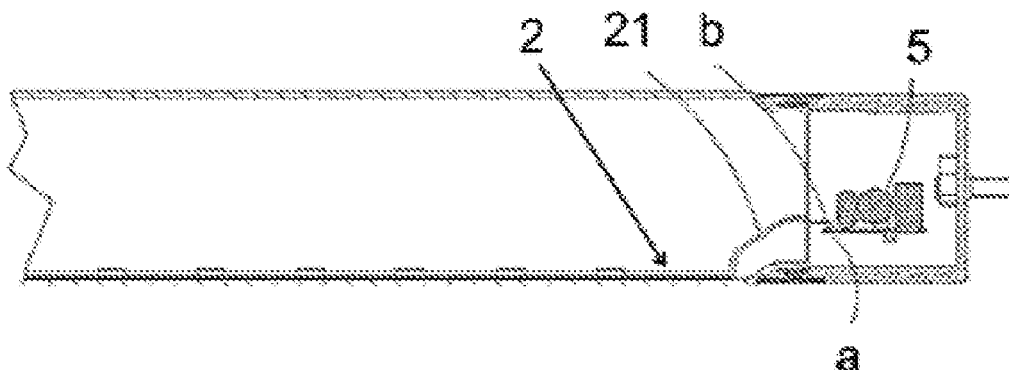

US 9,841,174 B2

**Related U.S. Application Data**

continuation-in-part of application No. 15/066,645, filed on Mar. 10, 2016, now Pat. No. 9,497,821, which is a continuation-in-part of application No. 14/865,387, filed on Sep. 25, 2015, now Pat. No. 9,609,711, said application No. 15/210,989 is a continuation-in-part of application No. 15/205,011, filed on Jul. 8, 2016, now Pat. No. 9,629,211, which is a continuation-in-part of application No. 15/150,458, filed on May 10, 2016, now Pat. No. 9,794,990, which is a continuation-in-part of application No. 14/865,387, filed on Sep. 25, 2015, now Pat. No. 9,609,711, and a continuation-in-part of application No. 14/699,138, filed on Apr. 29, 2015, now Pat. No. 9,480,109.

9,750,096	B2	8/2017	Xiong et al.
2002/0176262	A1	11/2002	Tripathi
2003/0102819	A1	6/2003	Min
2007/0127242	A1	6/2007	Allen et al.
2010/0096976	A1	4/2010	Park
2010/0102729	A1	4/2010	Katzir
2010/0181925	A1	7/2010	Ivey et al.
2010/0220469	A1	9/2010	Ivey et al.
2011/0043127	A1	2/2011	Yamasaki
2011/0057572	A1	3/2011	Kit et al.
2011/0121756	A1	5/2011	Thomas et al.
2011/0148313	A1	6/2011	Ramaker
2011/0149563	A1	6/2011	Hsia et al.
2011/0176297	A1	7/2011	Hsia et al.
2011/0228526	A1	9/2011	Hartikka et al.
2011/0260614	A1	10/2011	Hartikka et al.
2012/0181952	A1	7/2012	Rooer
2012/0299501	A1	11/2012	Kost et al.
2012/0300445	A1	11/2012	Chu et al.
2012/0313540	A1	12/2012	Lin
2013/0127327	A1	5/2013	Heil et al.
2013/0147350	A1	6/2013	Yang
2013/0320869	A1	12/2013	Jans
2013/0335959	A1	12/2013	Hsia et al.
2014/0035463	A1	2/2014	Miyamichi Saburo
2014/0055029	A1	2/2014	Jans
2014/0117853	A1	5/2014	Miyamichi
2014/0239827	A1	8/2014	Park
2014/0239834	A1	8/2014	Choi et al.
2014/0265900	A1	9/2014	Sadwick et al.
2015/0061520	A1*	3/2015	Tao

(30) **Foreign Application Priority Data**

Sep. 18, 2015	(CN)	2015 1 0595173
Oct. 8, 2015	(CN)	2015 1 0645134
Oct. 30, 2015	(CN)	2015 1 0726365
Nov. 27, 2015	(CN)	2015 1 0848766
Jan. 22, 2016	(CN)	2016 1 0044148
Mar. 9, 2016	(CN)	2016 1 0132513
Mar. 14, 2016	(CN)	2016 1 0142140
Jun. 20, 2016	(CN)	2016 1 0452437

(51) **Int. Cl.**

<i>F21V 25/02</i>	(2006.01)
<i>F21K 9/272</i>	(2016.01)
<i>F21V 15/015</i>	(2006.01)
<i>F21K 9/278</i>	(2016.01)
<i>H05B 33/08</i>	(2006.01)
<i>F21V 3/02</i>	(2006.01)
<i>F21V 23/02</i>	(2006.01)
<i>F21V 29/10</i>	(2015.01)
<i>F21Y 115/10</i>	(2016.01)
<i>F21Y 103/10</i>	(2016.01)

2015/0077001	A1	3/2015	Takahashi
2015/0173138	A1	6/2015	Roberts
2015/0176770	A1	6/2015	Wilcox et al.
2016/0081147	A1	3/2016	Guang
2016/0198535	A1	7/2016	Ye et al.
2016/0219658	A1	7/2016	Xiong et al.
2016/0255699	A1	9/2016	Ye et al.
2016/0270163	A1	9/2016	Hu et al.
2016/0270164	A1	9/2016	Xiong et al.
2016/0270165	A1	9/2016	Xiong et al.
2016/0270166	A1	9/2016	Xiong et al.
2016/0270173	A1	9/2016	Xiong
2016/0270184	A1	9/2016	Xiong et al.
2016/0309550	A1	10/2016	Xiong et al.
2016/0381746	A1	12/2016	Ye et al.
2016/0381760	A1	12/2016	Xiong et al.
2017/0067627	A1	3/2017	Liu et al.
2017/0105263	A1	4/2017	Xiong et al.
2017/0164434	A1	6/2017	Xiong et al.

(52) **U.S. Cl.**

CPC ..... *F21V 15/015* (2013.01); *F21V 23/023* (2013.01); *F21V 29/10* (2015.01); *H05B 33/089* (2013.01); *H05B 33/0815* (2013.01); *H05B 33/0845* (2013.01); *H05B 33/0857* (2013.01); *F21Y 2103/10* (2016.08); *F21Y 2115/10* (2016.08)

FOREIGN PATENT DOCUMENTS

(56) **References Cited**

U.S. PATENT DOCUMENTS

8,796,943	B2	2/2014	Miyamichi
8,749,167	B2	6/2014	Hsia et al.
9,210,744	B2	12/2015	Carmen et al.
9,480,109	B2	10/2016	Ye et al.
9,497,821	B2	11/2016	Liu
9,521,718	B2	12/2016	Xiong et al.
9,526,145	B2	12/2016	Xiong et al.
9,587,817	B2	3/2017	Liu et al.
9,609,711	B2	3/2017	Jiang et al.
9,629,211	B2	4/2017	Xiong et al.
9,629,215	B2	4/2017	Xiong et al.
9,629,216	B2	4/2017	Jiang et al.
9,689,536	B2	6/2017	Xiong et al.

CN	102155642	8/2011	
CN	102355780	2/2012	
CN	102932997	2/2013	
CN	104735873	6/2015	
CN	106015996	A	10/2016
EP	2914065		9/2015
GB	2533683		6/2016
WO	WO2012139691		10/2012
WO	WO2013150417	A1	10/2013
WO	WO2014206785	A1	12/2014
WO	WO2015028329	A1	3/2015
WO	WO2015028639	A1	3/2015
WO	WO2015/066566	A1	5/2015
WO	WO 2015066566	A1 *	5/2015
WO	WO2017012514	A1	1/2017

..... F21V 25/00

\* cited by examiner

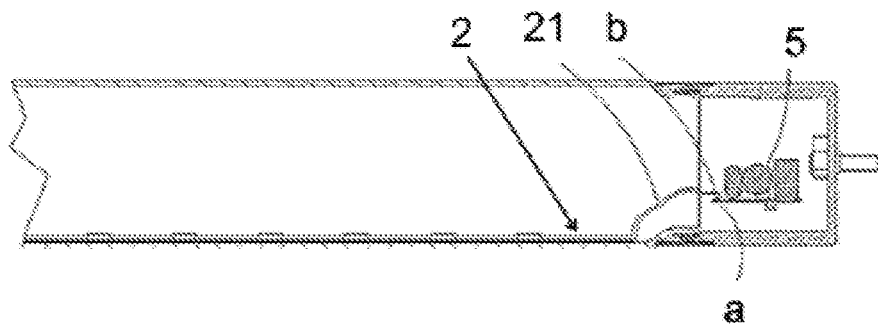

Fig. 1

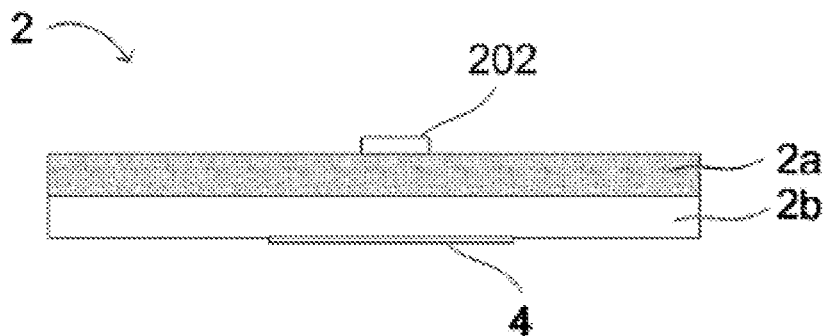

Fig. 2

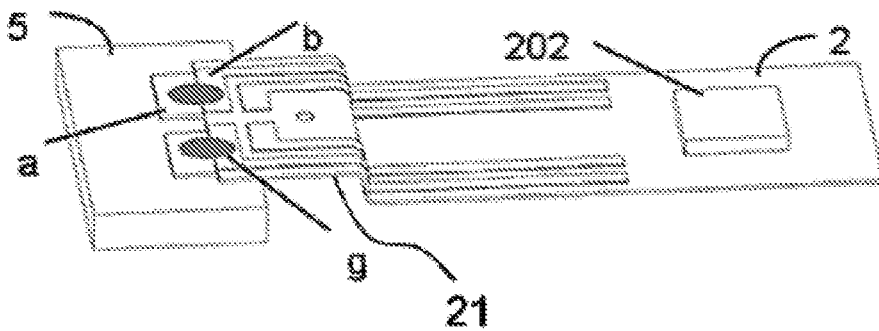

Fig. 3

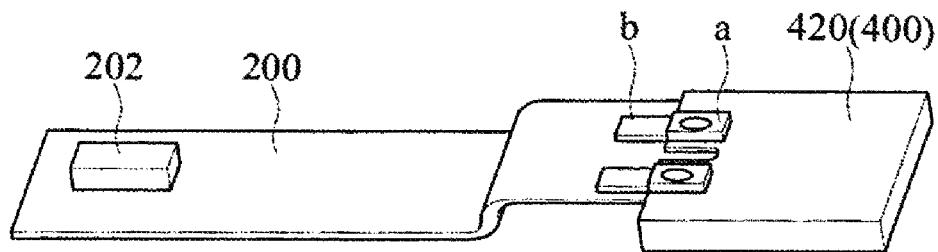

Fig. 4A

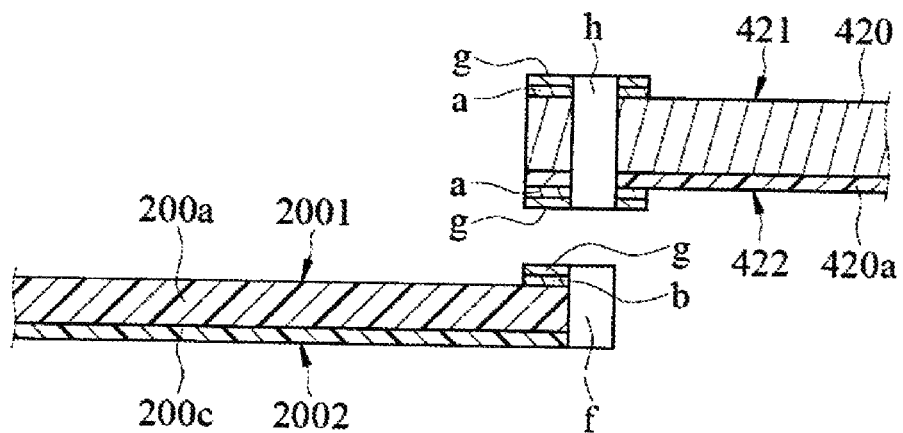

Fig. 4B

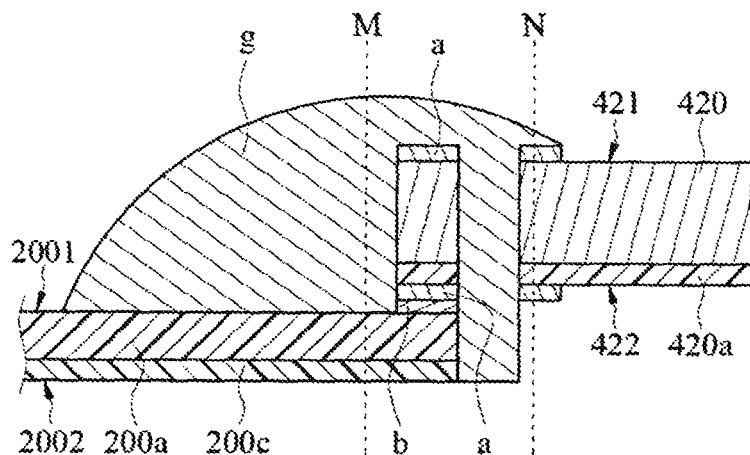

Fig. 4C

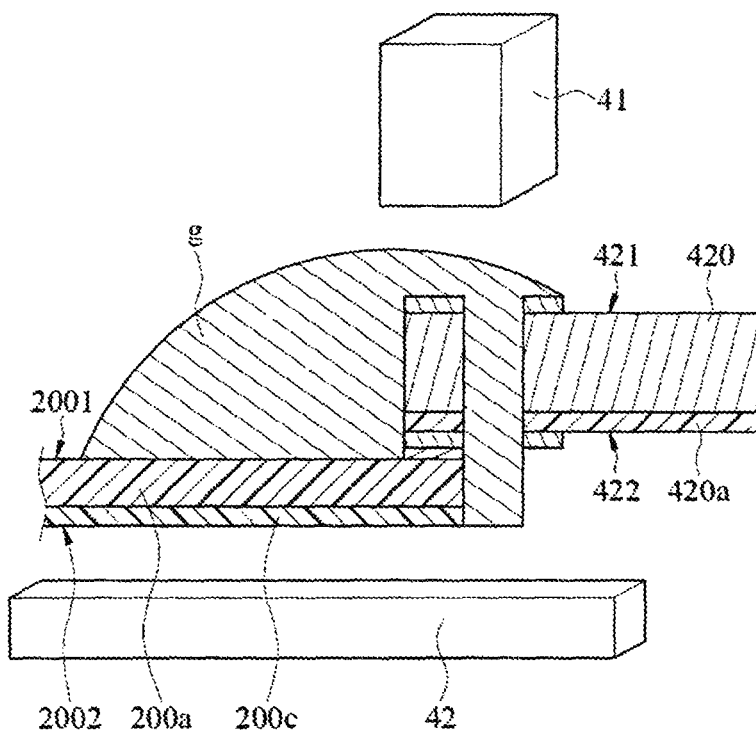

Fig. 4D

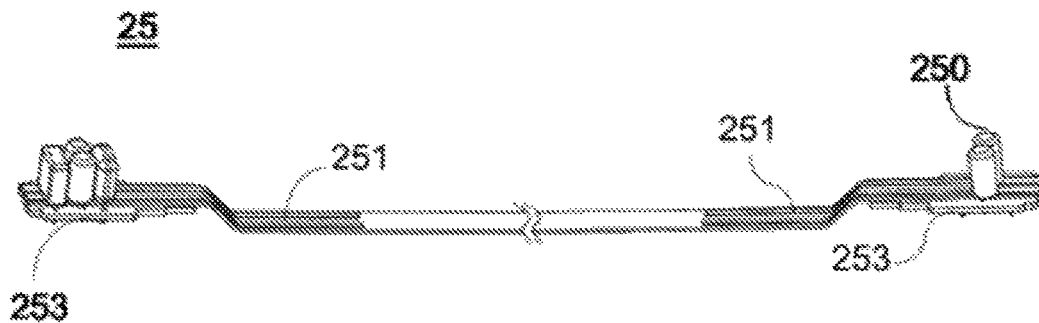

Fig. 5

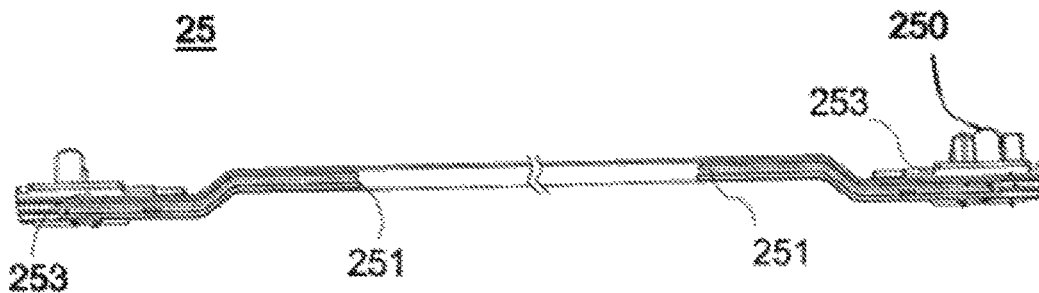

Fig. 6

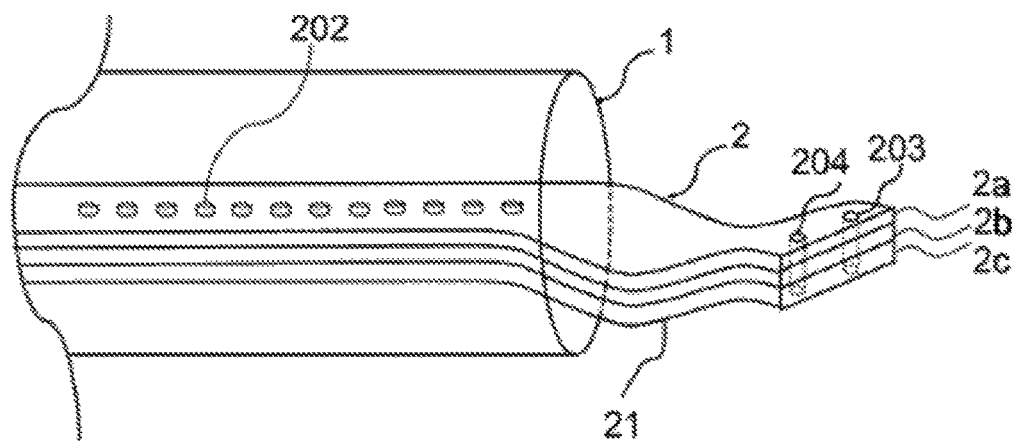

Fig. 7



Fig. 8A

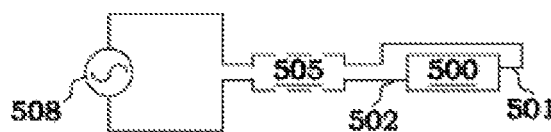

Fig. 8B

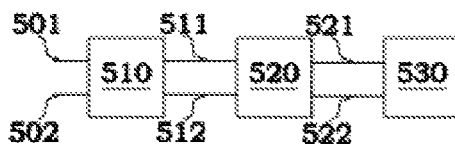

Fig. 8C

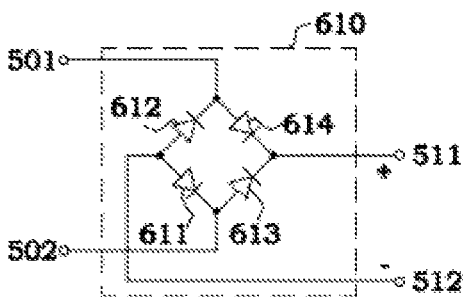

Fig. 9



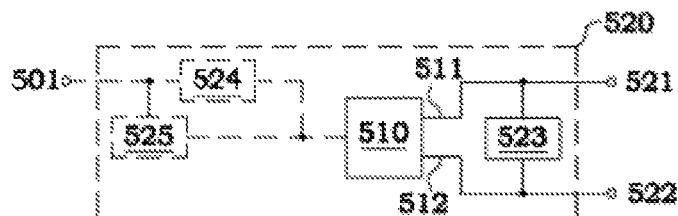

Fig. 10A

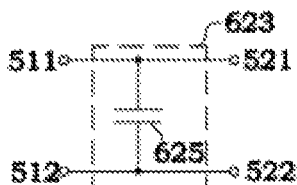

Fig. 10B

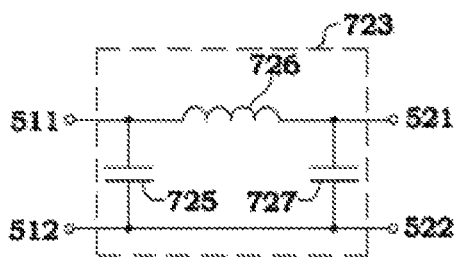

Fig. 10C

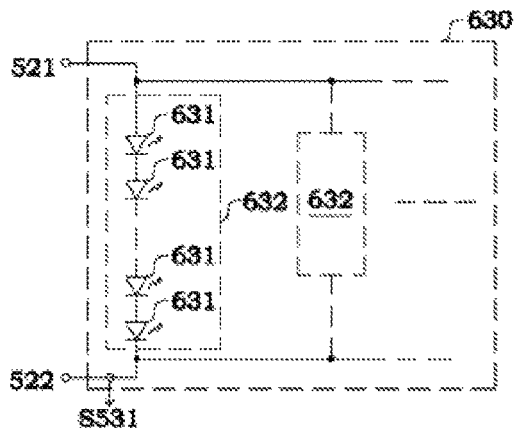

Fig. 11A

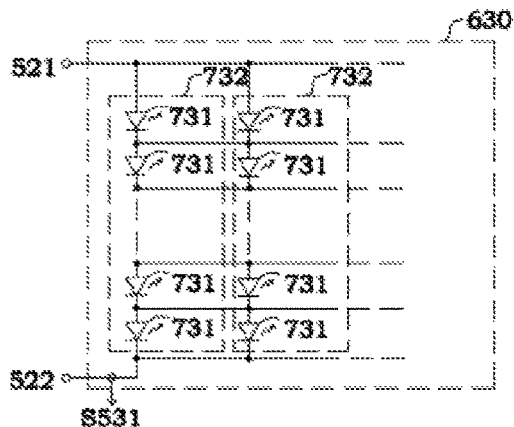

Fig. 11B

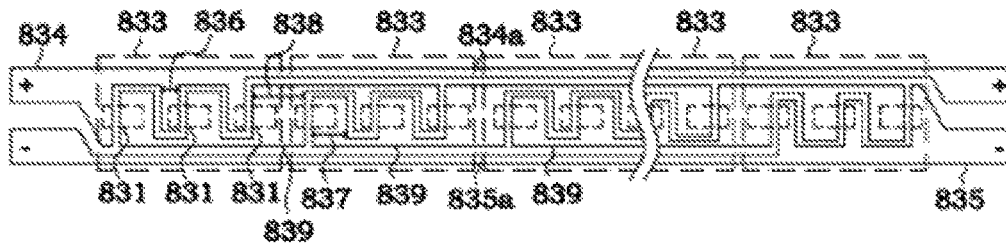

Fig. 11C

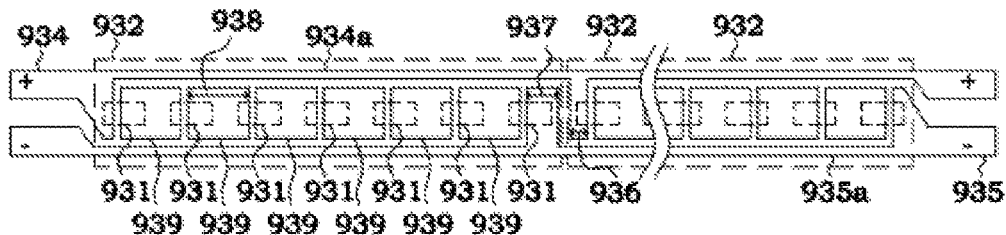

Fig. 11D

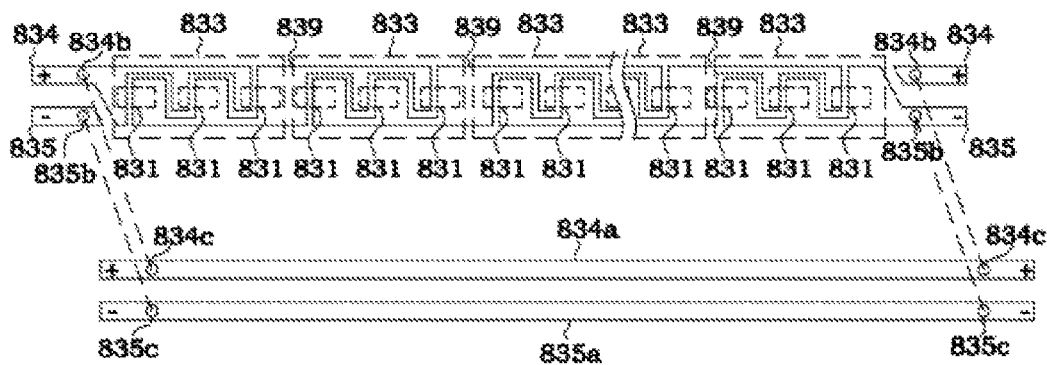

Fig. 11E

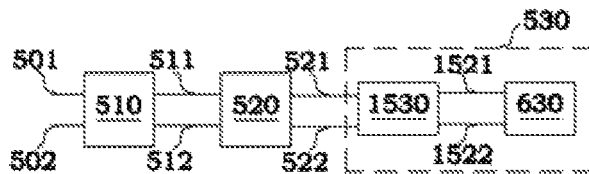

Fig. 12A

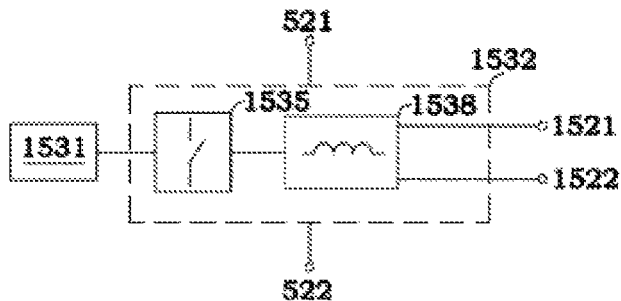

Fig. 12B

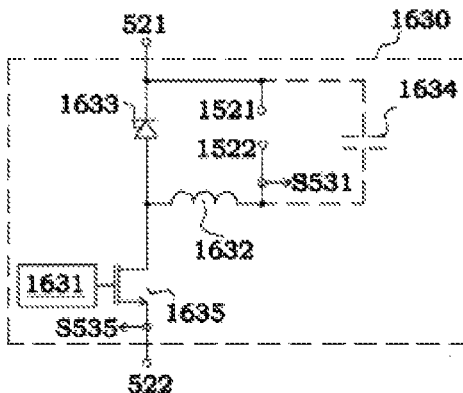

Fig. 12C

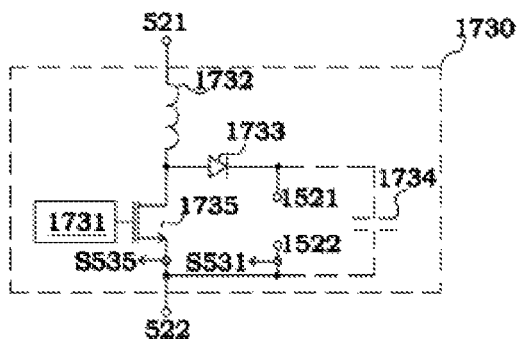

Fig. 12D

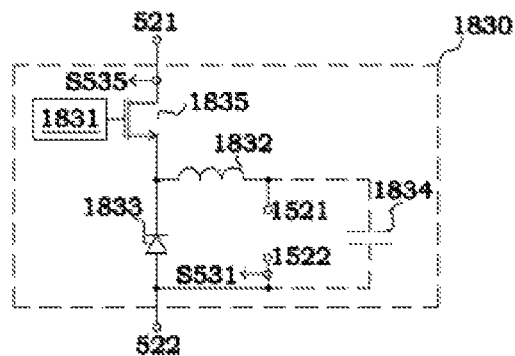

Fig. 12E

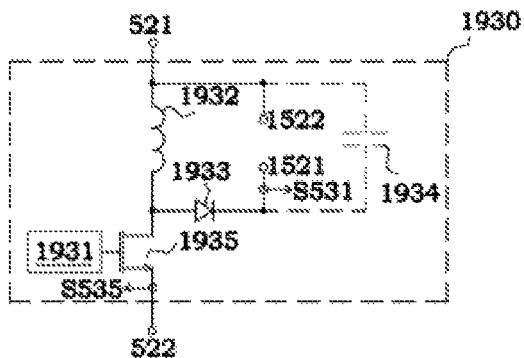

Fig. 12F

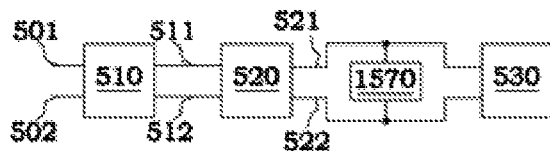

Fig. 13A

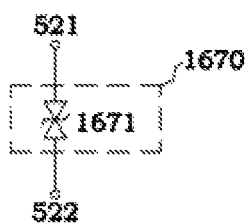

Fig. 13B

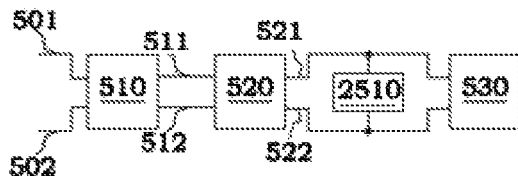

Fig. 14A

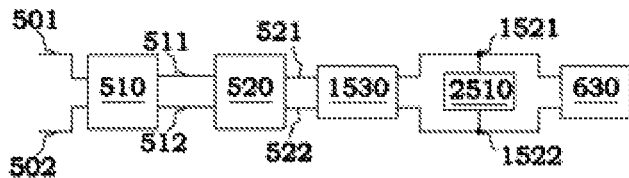

Fig. 14B

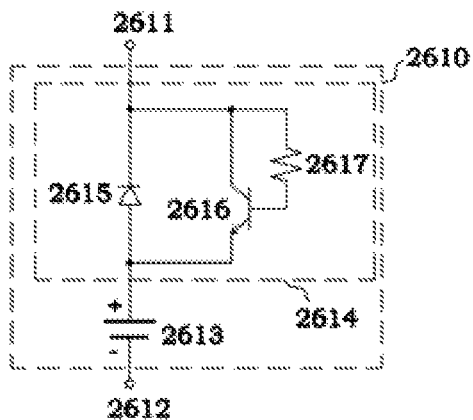

Fig. 14C

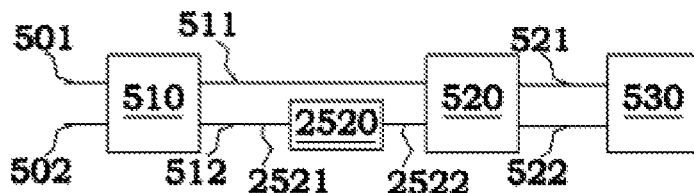

Fig. 15A

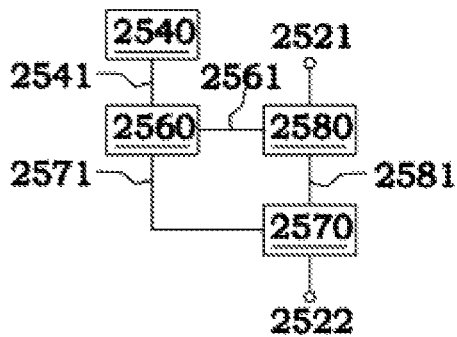

Fig. 15B

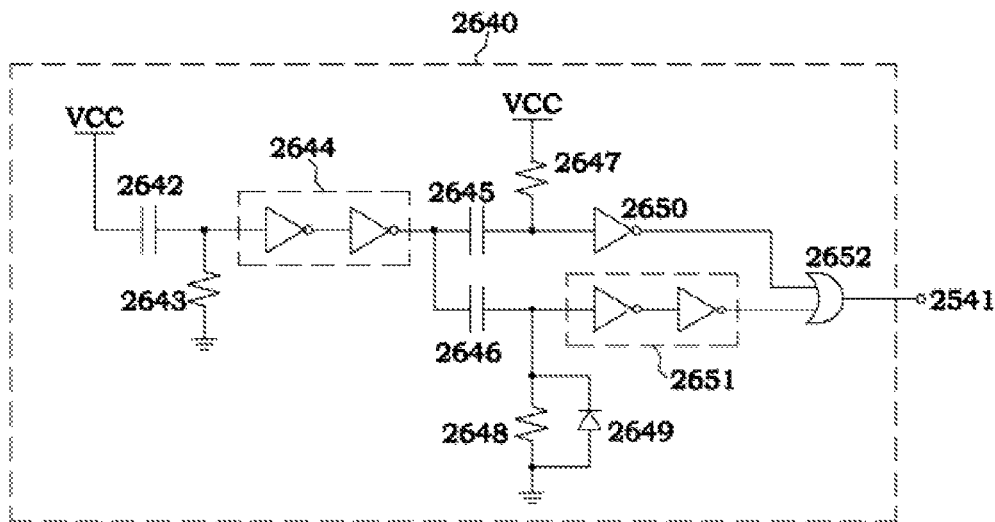

Fig. 15C

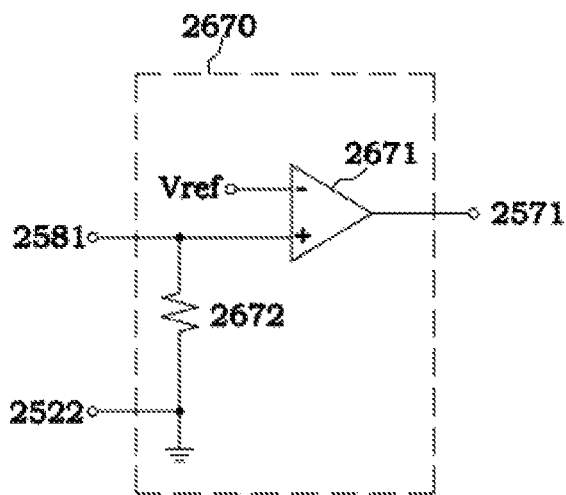

Fig. 15D



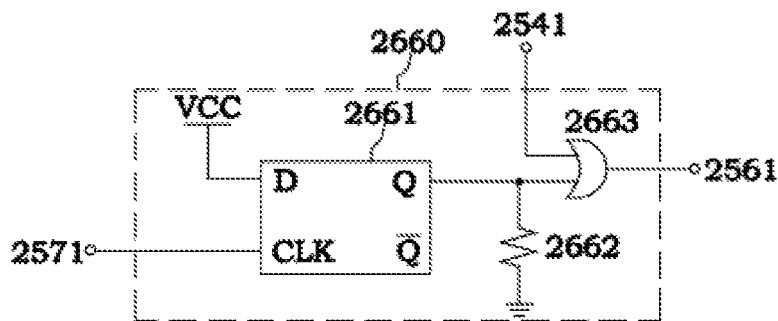

Fig. 15E

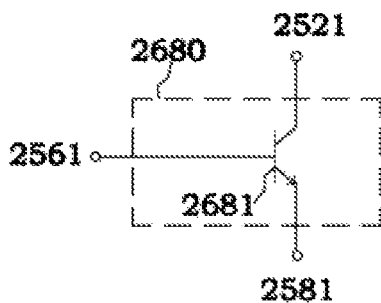

Fig. 15F

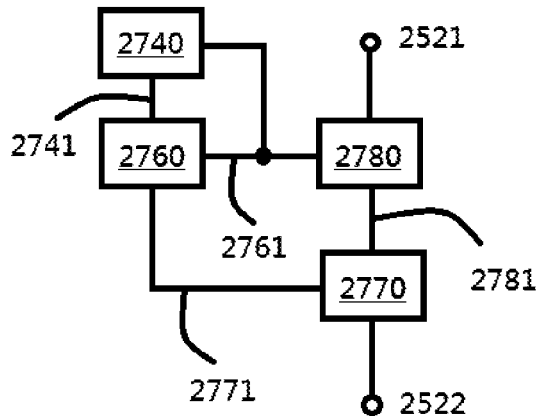

Fig. 15G

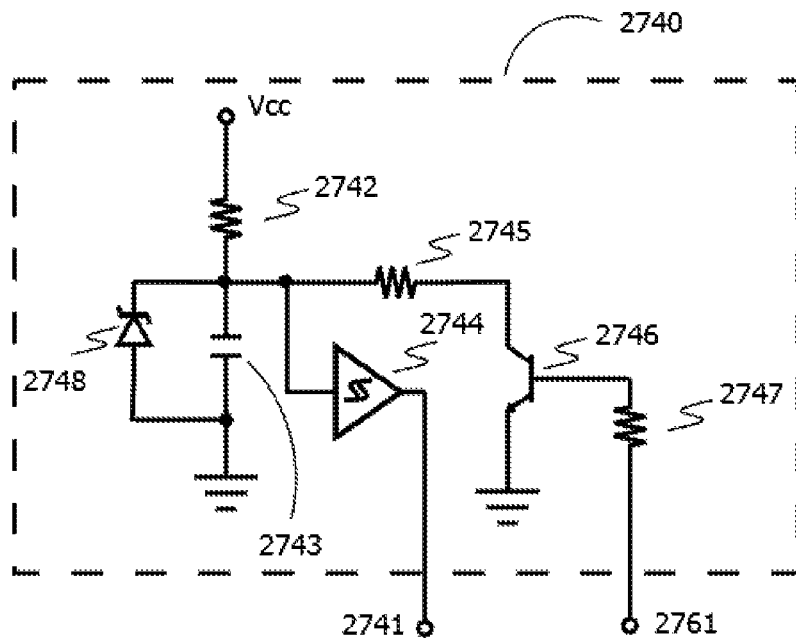

Fig. 15H

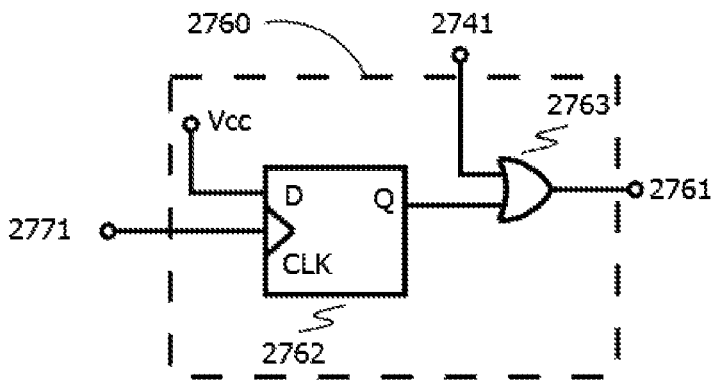

Fig. 15I

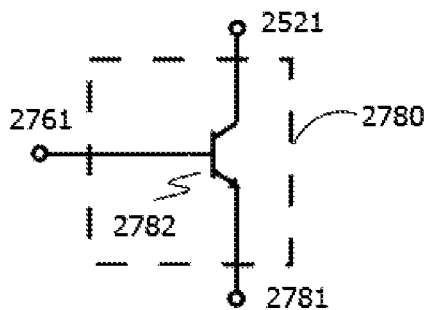

Fig. 15J

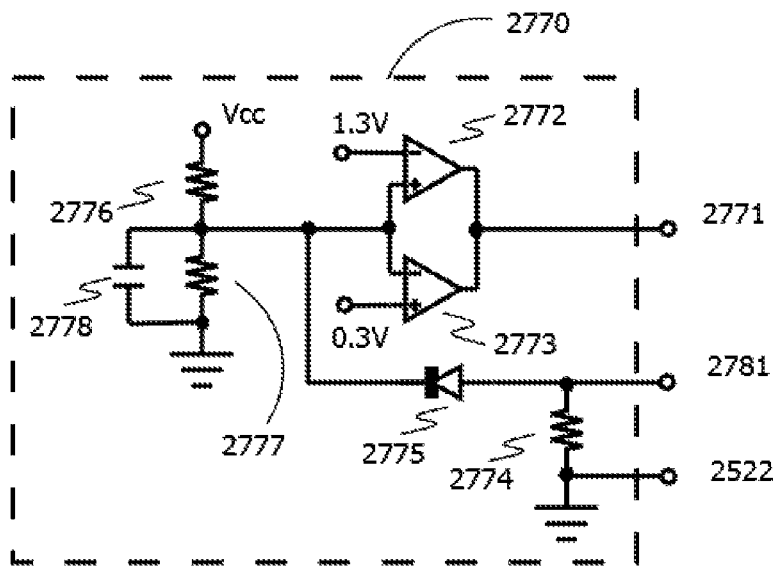

Fig. 15K

## US 9,841,174 B2

**1**  
**LED TUBE LAMP**

## RELATED APPLICATIONS

This application is a Continuation application of Ser. No. 15/210,989, filed on Jul. 15, 2016, the disclosure of which is incorporated in its entirety by reference herein, which is a Continuation-In-Part application of U.S. patent application Ser. No. 15/066,645, filed on Mar. 10, 2016, the disclosure of which is incorporated in its entirety by reference herein, which is a Continuation-In-Part application of U.S. patent application Ser. No. 14/865,387, filed on Sep. 25, 2015, the disclosure of which is incorporated in its entirety by reference herein.

In addition, U.S. patent application Ser. No. 15/066,645, from which U.S. patent application Ser. No. 15/210,989 claims priority as a Continuation-In-Part also claims priority under 35 U.S.C. 119(e) to Chinese Patent Applications Nos.: CN 201510530110.3 filed on 2015 Aug. 26; and CN 201510645134.3 filed on 2015 Oct. 8, the disclosures of which are incorporated herein in their entirety by reference.

In addition, U.S. patent application Ser. No. 15/210,989, from which this application claims priority as a Continuation is also a Continuation-In-Part application of U.S. patent application Ser. No. 15/205,011, filed on Jul. 8, 2016, the disclosure of which is incorporated in its entirety by reference herein, which is a Continuation-In-Part application of U.S. patent application Ser. No. 15/150,458, filed on May 10, 2016, the disclosure of which is incorporated in its entirety by reference herein, which is a Continuation-In-Part Application of U.S. patent application Ser. No. 14/865,387, filed on Sep. 25, 2015, the disclosure of which is incorporated in its entirety by reference herein, which claims priority under 35 U.S.C. 119(e) to the following Chinese Patent Applications filed in the Chinese Patent Office: CN 201510557717.0 filed on 2015 Sep. 6; and CN 201510595173.7 filed on 2015 Sep. 18, the disclosures of which U.S. and Chinese patent applications are incorporated herein by reference in their entirety. U.S. patent application Ser. No. 15/150,458, filed on 2016 May 10 is also a Continuation-In-Part application of U.S. patent application Ser. No. 14/699,138, filed on 2015 Apr. 29, now U.S. Pat. No. 9,480,109, the disclosures of which are incorporated herein by reference in their entirety.

In addition, U.S. patent application Ser. No. 15/210,989, from which this application claims priority as a Continuation also claims priority under 35 U.S.C. 119(e) to Chinese Patent Application Nos.: CN 201510848766.X, filed on Nov. 27, 2015; CN 201610132513.7, filed on Mar. 9, 2016; CN 201610142140.1, filed on Mar. 14, 2016; and CN 201610452437.8, filed on Jun. 20, 2016, the disclosures of which are incorporated herein in their entirety by reference. In addition, U.S. patent application Ser. No. 15/210,989, from which this application claims priority as a Continuation also claims priority under 35 U.S.C. 119(e) to Chinese Patent Application Nos.: CN 201510726365.7, filed on Oct. 30, 2015; and CN 201610044148.4, filed on Jan. 22, 2016, the disclosures of which are incorporated herein in their entirety by reference.

## TECHNICAL FIELD

The disclosed embodiments relate to the features of light emitting diode (LED) lighting. More particularly, the disclosed embodiments describe various improvements for LED tube lamps.

**2**  
**BACKGROUND**

LED lighting technology is rapidly developing to replace traditional incandescent and fluorescent lighting. LED tube lamps are mercury-free in comparison with fluorescent tube lamps that need to be filled with inert gas and mercury. Thus, it is not surprising that LED tube lamps are becoming a highly desired illumination option among different available lighting systems used in homes and workplaces, which used to be dominated by traditional lighting options such as compact fluorescent light bulbs (CFLs) and fluorescent tube lamps. Benefits of LED tube lamps include improved durability and longevity and far less energy consumption. Therefore, when taking into account all factors, they would typically be considered as a cost effective lighting option.

Typical LED tube lamps have a lamp tube, a circuit board disposed inside the lamp tube with light sources being mounted on the circuit board, and end caps accompanying a power supply provided at two ends of the lamp tube with the electricity from the power supply transmitting to the light sources through the circuit board. However, existing LED tube lamps have certain drawbacks. For example, the typical circuit board is rigid and allows the entire lamp tube to maintain a straight tube configuration when the lamp tube is partially ruptured or broken, and this gives the user a false impression that the LED tube lamp remains usable and is likely to cause the user to be electrically shocked upon handling or installation of the LED tube lamp.

Conventional circuit design of LED tube lamps typically doesn't provide suitable solutions for complying with relevant certification standards. For example, since there are usually no electronic components in a fluorescent lamp, it's fairly easy for a fluorescent lamp to be certified under EMI (electromagnetic interference) standards and safety standards for lighting equipment as provided by Underwriters Laboratories (UL). However, there are a considerable number of electronic components in an LED tube lamp, and therefore consideration of the impacts caused by the layout (structure) of the electronic components is important, resulting in difficulties in complying with such standards.

Further, the driving of an LED uses a DC driving signal, but the driving signal for a fluorescent lamp is a low-frequency, low-voltage AC signal as provided by an AC powerline, a high-frequency, high-voltage AC signal provided by a ballast, or even a DC signal provided by a battery for emergency lighting applications. Since the voltages and frequency spectrums of these types of signals differ significantly, simply performing a rectification to produce the required DC driving signal in an LED tube lamp may not achieve the LED tube lamp's compatibility with traditional driving systems of a fluorescent lamp.

Moreover, when an LED tube lamp has an architecture with dual-end power supply and one end cap thereof is inserted into a lamp socket but the other is not, an electric shock situation could take place for the user touching the metal or conductive part of the end cap which has not been inserted into the lamp socket.

Currently, LED tube lamps used to replace traditional fluorescent lighting devices can be primarily categorized into two types. One is for ballast-compatible LED tube lamps, e.g., T-LED lamp, which directly replaces fluorescent tube lamps without changing any circuit on the lighting device; and the other one is for ballast by-pass LED tube lamps, which omit traditional ballast on their circuit and directly connect the commercial electricity to the LED tube

## US 9,841,174 B2

3

lamp. The latter LED tube lamp is suitable for the new surroundings in fixtures with new driving circuits and LED tube lamps.

## SUMMARY

It's specially noted that the present disclosure may actually include one or more inventions claimed currently or not yet claimed, and for avoiding confusion due to unnecessarily distinguishing between those possible inventions at the stage of preparing the specification, the possible plurality of inventions herein may be collectively referred to as "the (present) invention" herein.

Various embodiments are summarized in this section, and may be described with respect to the "present invention," which terminology is used to describe certain presently disclosed embodiments, whether claimed or not, and is not necessarily an exhaustive description of all possible embodiments, but rather is merely a summary of certain embodiments. Certain of the embodiments described below as various aspects of the "present invention" can be combined in different manners to form an LED tube lamp or a portion thereof.

The present disclosure provides a novel LED tube lamp, and aspects thereof.

According to certain embodiments, an installation detection module configured in a light-emitting diode (LED) tube lamp to detect an installation state between the LED tube lamp and a lamp socket is provided. The installation detection module includes: a detection pulse generating module, configured to generate a first pulse signal; a detection result latching circuit, configured to receive and output the first pulse signal; a switch circuit, configured to receive the first pulse signal from the detection result latching circuit, and configured to maintain a conductive state during the first pulse to cause a power loop of the LED tube lamp to be conductive; and a detection determining circuit, configured to detect a first sampling signal on the power loop so as to determine the installation state between the LED tube lamp and the lamp socket.

In some embodiments, the detection determining circuit outputs a first high level signal when the first sampling signal is greater than or equal to a predefined signal, the detection result latching circuit receives the first high level signal and outputs a second high level signal, the switch circuit receives the second high level signal and maintains the conductive state to cause the power loop to remain conductive.

In some embodiments, the detection determining circuit outputs a first low level signal when the first sampling signal is smaller than a predefined signal, the detection result latching circuit receives the first low level signal and outputs a second low level signal, the switch circuit receives the second low level signal and maintains an off state to cause the power loop to remain open.

In some embodiments, the detection pulse generating module further generates a second pulse signal when the power loop remains open, the detection result latching circuit receives and outputs the second pulse signal, the switch circuit receives the second pulse signal from the detection result latching circuit, and changes the off state to the conductive state again during the second pulse to cause the power loop to be conductive once more, the detection determining circuit newly detects a second sampling signal on the power loop so as to determine the installation state between the LED tube lamp and the lamp socket.

4

In some embodiments, the detection determining circuit outputs a first high level signal when the second sampling signal is greater than or equal to the predefined signal, the detection result latching circuit receives the first high level signal and outputs a second high level signal, the switch circuit receives the second high level signal and maintains the conductive state to cause the power loop to remain conductive.

In some embodiments, the detection determining circuit outputs the first low level signal when the second sampling signal is smaller than the predefined signal, the detection result latching circuit receives the first low level signal and outputs the second low level signal, the switch circuit receives the second low level signal and maintains the off state to cause the power loop to remain open.

In some embodiments, the detection pulse generating module includes: a first capacitor, one end connected to a driving signal; a first resistor, one end connected to the other end of the first capacitor, the other end of the first resistor grounded; a first buffer, having an input end and an output end, the input end connected to the other end of the first capacitor; a second capacitor, one end connected to the output end of the first buffer; a third capacitor, one end connected to the output end of the first buffer; a second resistor, one end connected to the driving signal, the other end of the second resistor connected to the other end of the second capacitor; a third resistor, one end connected to the other end of the third capacitor, the other end of the third resistor grounded; a first diode, having an anode and a cathode, the anode connected to the other end of the third resistor, the cathode connected to the one end of the third resistor; a first inverter, having an input end and an output end, the input end connected to the other end of the second capacitor; a second buffer, having an input end and an output end, the input end connected to the other end of the third capacitor; and a first OR gate, having a first input end, a second input end, and an output end, the first input end connected to the output end of the first inverter, the second input end connected to the output end of the second buffer, the output end of the first OR gate connected to the detection result latching circuit.

In certain embodiments, the first and the second buffers respectively include two inverters connected in series.

In some embodiments, the detection result latching circuit includes: a first D flip-flop, having a data input end, a clock input end, and an output end, the data input end connected to the driving signal, the clock input end connected to the detection determining circuit; a fourth resistor, one end connected to the output end of the first D flip-flop, the other end of the fourth resistor grounded; and a second OR gate, having a first input end, a second input end, and an output end, the first input end connected to the output end of the first OR gate, the second input end connected to the output end of the first D flip-flop, the output end of the second OR gate connected to the switch circuit.

In some embodiments, the switch circuit includes: a first transistor, having a base, a collector, and an emitter, the base connected to the output end of the second OR gate, the collector connected to one end of the power loop, the emitter connected to the detection determining circuit.

In some embodiments, the detection determining circuit includes: a fifth resistor, one end connected to the emitter of the first transistor, the other end of the fifth resistor connected to the other end of the power loop; and a first comparator, having a first input end, a second input end, and an output end, the first input end connected to the predefined signal, the second input end connected to the one end of the

## US 9,841,174 B2

5

fifth resistor, the output end of the first comparator connected to the clock input end of the first D flip-flop.

In some embodiments, the detection pulse generating module includes: a sixth resistor, one end connected to a driving signal; a fourth capacitor, one end connected to the other end of the sixth resistor, the other end of the fourth capacitor grounded; a Schmitt trigger, having an input end and an output end, the input end connected to the one end of the fourth capacitor, the output end connected to the detection result latching circuit; a seventh resistor, one end connected to the one end of the fourth capacitor; a second transistor, having a base, a collector, and an emitter, the collector connected to the other end of the seventh resistor, the emitter grounded; and an eighth resistor, one end connected to the base of the second transistor, the other end of the eighth resistor connected to the detection result latching circuit and the switch circuit.

In certain embodiments, the detection pulse generating module further includes: a Zener diode, having an anode and a cathode, the anode connected to the other end of the fourth capacitor, the cathode connected to the one end of the fourth capacitor.

In some embodiments, the detection result latching circuit includes: a second D flip-flop, having a data input end, a clock input end, and an output end, the data input end connected to the driving signal, the clock input end connected to the detection determining circuit; and a third OR gate, having a first input end, a second input end, and an output end, the first input end connected to the output end of the Schmitt trigger, the second input end connected to the output end of the second D flip-flop, the output end of the third OR gate connected to the other end of the eighth resistor and the switch circuit.

In some embodiments, the switch circuit includes: a third transistor, having a base, a collector, and an emitter, the base connected to the output end of the third OR gate, the collector connected to one end of the power loop, the emitter connected to the detection determining circuit.

In some embodiments, the detection determining circuit includes: a ninth resistor, one end connected to the emitter of the third transistor, the other end of the ninth resistor connected to the other end of the power loop; and a second comparator, having a first input end, a second input end, and an output end, the first input end connected to the predefined signal, the second input end connected to the one end of the ninth resistor, the output end of the second comparator connected to the clock input end of the second D flip-flop.

In some embodiments, the detection determining circuit includes: a ninth resistor, one end connected to the emitter of the third transistor, the other end of the ninth resistor connected to the other end of the power loop; a second diode, having an anode and a cathode, the anode connected to the one end of the ninth resistor; a second comparator, having a first input end, a second input end, and an output end, the first input end connected to the predefined signal, the second input end connected to the cathode of the second diode, the output end of the second comparator connected to the clock input end of the second D flip-flop; a third comparator, having a first input end, a second input end, and an output end, the first input end connected to the cathode of the second diode, the second input end connected to another predefined signal, the output end of the third comparator connected to the clock input end of the second D flip-flop; a tenth resistor, one end connected to the driving signal; an eleventh resistor, one end connected to the other end of the tenth resistor and the second input end of the second

6

comparator, the other end of the eleventh resistor grounded; and a fifth capacitor, connected to the eleventh resistor in parallel.

In certain embodiments, a period of the first pulse signal is between 10 microseconds-1 millisecond, a period of the second pulse signal is between 10 microseconds-1 millisecond.

In certain embodiments, a time interval between the first and the second pulse signals includes  $(X+Y)(T/2)$ , where T is the cycle of the driving signal, X is an integer which is bigger than or equal to zero,  $0 < Y < 1$ .

In certain embodiments, a period of the first pulse signal is between 1 microsecond-100 microseconds, a period of the second pulse signal is between 1 microsecond-100 microseconds.

In certain embodiments, a time interval between the first and the second pulse signals is between 3 milliseconds-500 milliseconds.

According to some embodiments, the LED tube lamp includes an LED module disposed on a bendable circuit sheet electrically connected to a printed circuit board the installation detection module configured on, wherein the bendable circuit sheet is disposed below the printed circuit board to be electrically connected to the printed circuit board by soldering.

According to some embodiments, the bendable circuit sheet includes a first surface and a second surface, and a plurality of first soldering pads are formed on the first surface of the bendable circuit sheet. The printed circuit board includes a top surface and a bottom surface, and a plurality of second soldering pads are formed on the top surface of the printed circuit board, and a plurality of third soldering pads respectively corresponding to the plurality of second soldering pads are formed on the bottom surface of the printed circuit board. The plurality of first soldering pads on the first surface of the bendable circuit sheet are electrically connected to the plurality of third soldering pads on the bottom surface of the printed circuit board by soldering.

According to some embodiments, the printed circuit board further includes a plurality of through holes correspondingly passing through the plurality of second and third soldering pads on the top surface and the bottom surface of the printed circuit board, wherein at least one of the plurality of through holes is filled with a soldering material to electrically connect to the bendable circuit sheet during a soldering process.

According to some embodiments, the bendable circuit sheet further includes at least one notch disposed on an edge of an end of the bendable circuit sheet, the at least one notch aligned with the at least one of the plurality of through holes and soldered to the printed circuit board.

According to some embodiments, the present invention further provides an installation detection module configured in a light-emitting diode (LED) tube lamp to detect an installation state between the LED tube lamp and a lamp socket, the installation detection module includes: a first circuit, configured to generate a first pulse signal; a second circuit, configured to receive and output the first pulse signal; a third circuit, configured to receive the first pulse signal from the second circuit, and configured to maintain a conductive state during the first pulse to cause a power loop of the LED tube lamp to be conductive; and a fourth circuit, configured to detect a first sampling signal on the power loop so as to determine the installation state between the LED tube lamp and the lamp socket.

According to some embodiments, the present invention further provides a detection method adopted by a light-

## US 9,841,174 B2

7

emitting device (LED) tube lamp for preventing a user from electric shock when the LED tube lamp is being installed on a lamp socket. The detection method includes: generating a first pulse signal by a detection pulse generating module, wherein the detection pulse generating module is configured in the LED tube lamp; receiving the first pulse signal through a detection result latching circuit by a switch circuit, and making the switch circuit conducting during the first pulse signal to cause a power loop of the LED tube lamp to be conductive, wherein the switch circuit is on the power loop; and detecting a first sampling signal on the power loop by a detection determining circuit as the power loop being conductive, and comparing the first sampling signal with a predefined signal, wherein when the first sampling signal is greater than or equal to the predefined signal, the detection method further includes: outputting a first high level signal by the detection determining circuit; receiving the first high level signal by the detection result latching circuit and outputting a second high level signal; and receiving the second high level signal by the switch circuit and maintaining a conductive state to cause the power loop to remain conductive.

In some embodiments, when the first sampling signal is smaller than the predefined signal, the detection method further includes: outputting a first low level signal by the detection determining circuit; receiving the first low level signal by the detection result latching circuit and outputting a second low level signal; and receiving the second low level signal by the switch circuit and maintaining an off state to cause the power loop to remain open.

In some embodiments, when the power loop remains open, the detection method further includes: generating a second pulse signal by the detection pulse generating module; receiving the second pulse signal through the detection result latching circuit by the switch circuit, and making the switch circuit conducting again during the second pulse signal to cause the power loop to be conductive once more; and detecting a second sampling signal on the power loop by the detection determining circuit as the power loop being conductive once more, and comparing the second sampling signal with the predefined signal, wherein when the second sampling signal is greater than or equal to the predefined signal, the detection method further includes: outputting the first high level signal by the detection determining circuit; receiving the first high level signal by the detection result latching circuit and outputting the second high level signal; and receiving the second high level signal by the switch circuit and maintaining the conductive state to cause the power loop to remain conductive.

In some embodiments, when the second sampling signal is smaller than the predefined signal, the detection method further includes: outputting the first low level signal by the detection determining circuit; receiving the first low level signal by the detection result latching circuit and outputting the second low level signal; and receiving the second low level signal by the switch circuit and then maintaining the off state to cause the power loop to remain open.

According to the detection method described above, in some embodiments, a period (or a width) of the first pulse signal is between 10 microseconds-1 millisecond, a period (or a width) of the second pulse signal is between 10 microseconds-1 millisecond.

According to the detection method described above, in some embodiments, a time interval between the first and the second pulse signals (or a cycle of the pulse signal) includes  $(X+Y)(T/2)$ , where T is the cycle of the driving signal, X is an integer which is bigger than or equal to zero,  $0 < Y < 1$ .

8

According to the detection method described above, in some embodiments, a period (or a width) of the first pulse signal is between 1 microsecond-100 microseconds, a period (or a width) of the second pulse signal is between 1 microsecond-100 microseconds.

According to the detection method described above, in some embodiments, a time interval between the first and the second pulse signals (or a cycle of the pulse signal) is between 3 milliseconds-500 milliseconds.

## BRIEF DESCRIPTION OF THE FIGURES

FIG. 1 is a plane cross-sectional view schematically illustrating an LED tube lamp including an LED light strip that is a bendable circuit sheet with ends thereof passing across the transition region of the lamp tube of the LED tube lamp to be connected to a power supply according to some exemplary embodiments;

FIG. 2 is a plane cross-sectional view schematically illustrating a bi-layered structure of a bendable circuit sheet of an LED light strip of an LED tube lamp according to some exemplary embodiments;

FIG. 3 is a perspective view schematically illustrating a soldering pad of a bendable circuit sheet of an LED light strip for a solder connection with a power supply of an LED tube lamp according to some exemplary embodiments;

FIG. 4A is a perspective view of a bendable circuit sheet and a printed circuit board of a power supply soldered to each other in accordance with an exemplary embodiment;

FIGS. 4B, 4C, and 4D are diagrams of a soldering process of the bendable circuit sheet and the printed circuit board of the power supply of FIG. 4A in accordance with an exemplary embodiment;

FIG. 5 is a perspective view schematically illustrating a circuit board assembly composed of a bendable circuit sheet of an LED light strip and a printed circuit board of a power supply according to some exemplary embodiments;

FIG. 6 is a perspective view schematically illustrating another arrangement of a circuit board assembly, according to some exemplary embodiments;

FIG. 7 is a perspective view schematically illustrating a bendable circuit sheet of an LED light strip formed with two conductive wiring layers according to some exemplary embodiments;

FIG. 8A is a block diagram of an exemplary power supply system for an LED tube lamp according to some exemplary embodiments;

FIG. 8B is a block diagram of an exemplary power supply system for an LED tube lamp according to some exemplary embodiments;

FIG. 8C is a block diagram of an exemplary LED lamp according to some exemplary embodiments;

FIG. 9 is a schematic diagram of a rectifying circuit according to some exemplary embodiments;

FIGS. 10A-10C are block diagrams of exemplary filtering circuits according to some exemplary embodiments;

FIGS. 11A-11B are schematic diagrams of exemplary LED modules according to some exemplary embodiments;

FIGS. 11C-11E are plan views of a circuit layout of an LED module according to some exemplary embodiments;

FIG. 12A is a block diagram of an exemplary power supply module in an LED lamp according to some exemplary embodiments;

FIG. 12B is a block diagram of a driving circuit according to some exemplary embodiments;

FIGS. 12C-12F are schematic diagrams of exemplary driving circuits according to some exemplary embodiments;

## US 9,841,174 B2

9

FIG. 13A is a block diagram of an exemplary power supply module in an LED tube lamp according to some exemplary embodiments;

FIG. 13B is a schematic diagram of an over-voltage protection (OVP) circuit according to some exemplary 5  
embodiments;

FIG. 14A is a block diagram of an exemplary power supply module in an LED tube lamp according to some exemplary embodiments;

FIG. 14B is a block diagram of an exemplary power supply module in an LED tube lamp according to some exemplary 10  
embodiments;

FIG. 14C is a schematic diagram of an auxiliary power module according to some exemplary embodiments;

FIG. 15A is a block diagram of an LED tube lamp according to some exemplary embodiments;

FIG. 15B is a block diagram of an installation detection module according to some exemplary embodiments;

FIG. 15C is a schematic detection pulse generating module according to some exemplary embodiments;

FIG. 15D is a schematic detection determining circuit according to some exemplary embodiments;

FIG. 15E is a schematic detection result latching circuit according to some exemplary embodiments;

FIG. 15F is a schematic switch circuit according to some exemplary embodiments;

FIG. 15G is a block diagram of an installation detection module according to some exemplary embodiments;

FIG. 15H is a schematic detection pulse generating module according to some exemplary embodiments;

FIG. 15I is a schematic detection result latching circuit according to some exemplary embodiments;

FIG. 15J is a schematic switch circuit according to some exemplary 15  
embodiments; and

FIG. 15K is a schematic detection determining circuit according to some exemplary embodiments.

#### DETAILED DESCRIPTION OF THE EMBODIMENTS

The present disclosure provides a novel LED tube lamp. The present disclosure will now be described in the following 20  
embodiments with reference to the drawings. The following descriptions of various embodiments of this invention are presented herein for purpose of illustration and giving examples only. It is not intended to be exhaustive or to be limited to the precise form disclosed. These example embodiments are just that—examples—and many implementations and variations are possible that do not require the details provided herein. It should also be emphasized that the disclosure provides details of alternative examples, but such listing of alternatives is not exhaustive. Furthermore, any consistency of detail between various examples should not 25  
be interpreted as requiring such detail—it is impracticable to list every possible variation for every feature described herein. The language of the claims should be referenced in determining the requirements of the invention.

In the drawings, the size and relative sizes of components 30  
may be exaggerated for clarity. Like numbers refer to like elements throughout.

The terminology used herein is for the purpose of describing particular embodiments only and is not intended to be limiting of the invention. As used herein, the singular forms 35  
“a,” “an” and “the” are intended to include the plural forms as well, unless the context clearly indicates otherwise. As

10

used herein, the term “and/or” includes any and all combinations of one or more of the associated listed items and may be abbreviated as “/”.

It will be understood that, although the terms first, second, third etc. may be used herein to describe various elements, components, regions, layers, or steps, these elements, components, regions, layers, and/or steps should not be limited by these terms. Unless the context indicates otherwise, these terms are only used to distinguish one element, component, region, layer, or step from another element, component, region, or step, for example as a naming convention. Thus, a first element, component, region, layer, or step discussed below in one section of the specification could be termed a second element, component, region, layer, or step in another section of the specification or in the claims without departing from the teachings of the present invention. In addition, in certain cases, even if a term is not described using “first,” “second,” etc., in the specification, it may still be referred to as “first” or “second” in a claim in order to distinguish different claimed elements from each other.

It will be further understood that the terms “comprises” and/or “comprising,” or “includes” and/or “including” when used in this specification, specify the presence of stated features, regions, integers, steps, operations, elements, and/or components, but do not preclude the presence or addition of one or more other features, regions, integers, steps, operations, elements, components, and/or groups thereof.

It will be understood that when an element is referred to as being “connected” or “coupled” to or “on” another element, it can be directly connected or coupled to or on the other element or intervening elements may be present. In contrast, when an element is referred to as being “directly connected” or “directly coupled” to another element, there are no intervening elements present. Other words used to describe the relationship between elements should be interpreted in a like fashion (e.g., “between” versus “directly between,” “adjacent” versus “directly adjacent,” etc.). However, the term “contact,” as used herein refers to direct connection (i.e., touching) unless the context indicates otherwise.

Embodiments described herein will be described referring to plane views and/or cross-sectional views by way of ideal schematic views. Accordingly, the exemplary views may be modified depending on manufacturing technologies and/or tolerances. Therefore, the disclosed embodiments are not limited to those shown in the views, but include modifications in configuration formed on the basis of manufacturing processes. Therefore, regions exemplified in figures may have schematic properties, and shapes of regions shown in figures may exemplify specific shapes of regions of elements to which aspects of the invention are not limited.

Spatially relative terms, such as “beneath,” “below,” “lower,” “above,” “upper” and the like, may be used herein for ease of description to describe one element’s or feature’s relationship to another element(s) or feature(s) as illustrated in the figures. It will be understood that the spatially relative terms are intended to encompass different orientations of the device in use or operation in addition to the orientation depicted in the figures. For example, if the device in the figures is turned over, elements described as “below” or “beneath” other elements or features would then be oriented “above” the other elements or features. Thus, the term “below” can encompass both an orientation of above and below. The device may be otherwise oriented (rotated 90 degrees or at other orientations) and the spatially relative descriptors used herein interpreted accordingly.



## US 9,841,174 B2

11

Terms such as “same,” “equal,” “planar,” or “coplanar,” as used herein when referring to orientation, layout, location, shapes, sizes, amounts, or other measures do not necessarily mean an exactly identical orientation, layout, location, shape, size, amount, or other measure, but are intended to encompass nearly identical orientation, layout, location, shapes, sizes, amounts, or other measures within acceptable variations that may occur, for example, due to manufacturing processes. The term “substantially” may be used herein to emphasize this meaning, unless the context or other statements indicate otherwise. For example, items described as “substantially the same,” “substantially equal,” or “substantially planar,” may be exactly the same, equal, or planar, or may be the same, equal, or planar within acceptable variations that may occur, for example, due to manufacturing processes.

Terms such as “about” or “approximately” may reflect sizes, orientations, or layouts that vary only in a small relative manner, and/or in a way that does not significantly alter the operation, functionality, or structure of certain elements. For example, a range from “about 0.1 to about 1” may encompass a range such as a 0%-5% deviation around 0.1 and a 0% to 5% deviation around 1, especially if such deviation maintains the same effect as the listed range.

Unless otherwise defined, all terms (including technical and scientific terms) used herein have the same meaning as commonly understood by one of ordinary skill in the art to which this disclosure belongs. It will be further understood that terms, such as those defined in commonly used dictionaries, should be interpreted as having a meaning that is consistent with their meaning in the context of the relevant art and/or the present application, and will not be interpreted in an idealized or overly formal sense unless expressly so defined herein.

As used herein, items described as being “electrically connected” are configured such that an electrical signal can be passed from one item to the other. Therefore, a passive electrically conductive component (e.g., a wire, pad, internal electrical line, etc.) physically connected to a passive electrically insulative component (e.g., a prepreg layer of a printed circuit board, an electrically insulative adhesive connecting two devices, an electrically insulative underfill or mold layer, etc.) is not electrically connected to that component. Moreover, items that are “directly electrically connected,” to each other are electrically connected through one or more passive elements, such as, for example, wires, pads, internal electrical lines, resistors, etc. As such, directly electrically connected components do not include components electrically connected through active elements, such as transistors or diodes. Directly electrically connected elements may be directly physically connected and directly electrically connected.

Components described as thermally connected or in thermal communication are arranged such that heat will follow a path between the components to allow the heat to transfer from the first component to the second component. Simply because two components are part of the same device or board does not make them thermally connected. In general, components which are heat-conductive and directly connected to other heat-conductive or heat-generating components (or connected to those components through intermediate heat-conductive components or in such close proximity as to permit a substantial transfer of heat) will be described as thermally connected to those components, or in thermal communication with those components. On the contrary, two components with heat-insulative materials therebetween, which materials significantly prevent heat transfer

12

between the two components, or only allow for incidental heat transfer, are not described as thermally connected or in thermal communication with each other. The terms “heat-conductive” or “thermally-conductive” do not apply to any material that provides incidental heat conduction, but are intended to refer to materials that are typically known as good heat conductors or known to have utility for transferring heat, or components having similar heat conducting properties as those materials.

Embodiments may be described, and illustrated in the drawings, in terms of functional blocks, units and/or modules. Those skilled in the art will appreciate that these blocks, units and/or modules are physically implemented by electronic (or optical) circuits such as logic circuits, discrete components, analog circuits, hard-wired circuits, memory elements, wiring connections, and the like, which may be formed using semiconductor-based fabrication techniques or other manufacturing technologies. In the case of the blocks, units and/or modules being implemented by microprocessors or similar, they may be programmed using software (e.g., microcode) to perform various functions discussed herein and may optionally be driven by firmware and/or software. Alternatively, each block, unit and/or module may be implemented by dedicated hardware, or as a combination of dedicated hardware to perform some functions and a processor (e.g., one or more programmed microprocessors and associated circuitry) to perform other functions. Also, each block, unit and/or module of the embodiments may be physically separated into two or more interacting and discrete blocks, units and/or modules. Further, the blocks, units and/or modules of the various embodiments may be physically combined into more complex blocks, units and/or modules.

If any terms in this application conflict with terms used in any application(s) from which this application claims priority, or terms incorporated by reference into this application or the application(s) from which this application claims priority, a construction based on the terms as used or defined in this application should be applied.

Applicant’s prior U.S. patent application Ser. No. 14/724,840 (US PGPub No. 2016/0091156, the disclosure of which is incorporated herein in its entirety by reference), as an illustrated example, has addressed certain issues associated with the occurrence of electric shock in using a conventional LED lamp by providing a bendable circuit sheet. Some of the embodiments disclosed in U.S. patent application Ser. No. 14/724,840 can be combined with one or more of the example embodiments disclosed herein to further reduce the occurrence of electric shock in using an LED lamp.

Referring to FIG. 1, an LED tube lamp may include an LED light strip **2**. In certain embodiments, the LED light strip **2** may be formed from a bendable circuit sheet, for example that may be flexible. As described further below, the bendable circuit sheet, also described as a bendable circuit board, or a flexible or non-rigid tape. The bendable circuit sheet may have ends thereof passing across a transition region of the lamp tube of the LED tube lamp to be connected to a power supply **5**. In some embodiments, the ends of the bendable circuit sheet may be connected to a power supply in an end cap of the LED tube lamp. For example, the ends may be connected in a manner such that a portion of the bendable circuit sheet is bent away from the lamp tube and passes through the transition region where a lamp tube narrows, and such that the bendable circuit sheet vertically overlaps part of a power supply within an end cap of the LED tube lamp.

## US 9,841,174 B2

## 13

Referring to FIG. 2, to form an LED light strip 2, a bendable circuit sheet includes a wiring layer 2a with conductive effect. An LED light source 202 is disposed on the wiring layer 2a and is electrically connected to the power supply through the wiring layer 2a. Though only one LED light source 202 is shown in FIG. 2, a plurality of LED light sources 202, as shown in FIG. 1, may be arranged on the LED light strip 2. For example, light sources 202 may be arranged in one or more rows extending along a length direction of the LED light strip 2, which may extend along a length direction of the lamp tube as illustrated in FIG. 1. The wiring layer with conductive effect, in this specification, is also referred to as a conductive layer. Referring to FIG. 2 again, in one embodiment, the LED light strip 2 includes a bendable circuit sheet having a conductive wiring layer 2a and a dielectric layer 2b that are arranged in a stacked manner. In some embodiments, the wiring layer 2a and the dielectric layer 2b may have the same areas or the area of the wiring layer 2a may slightly be smaller than that of the dielectric layer 2b. The LED light source 202 is disposed on one surface of the wiring layer 2a, the dielectric layer 2b is disposed on the other surface of the wiring layer 2a that is away from the LED light sources 202 (e.g., a second, opposite surface from the first surface on which the LED light source 202 is disposed). The wiring layer 2a is electrically connected to a power supply 5 (as shown in FIG. 1) to carry direct current (DC) signals. In some embodiments, the surface of the dielectric layer 2b away from the wiring layer 2a (e.g., a second surface of the dielectric layer 2b opposite a first surface facing the wiring layer 2a) is fixed to an inner circumferential surface of a lamp tube, for example, by means of an adhesive sheet 4. The portion of the dielectric layer 2b fixed to the inner circumferential surface of the lamp tube 1 may substantially conform to the shape of the inner circumferential surface of the lamp tube 1. The wiring layer 2a can be a metal layer or a power supply layer including wires such as copper wires.

A power supply as described herein may include a circuit that converts or generates power based on a received voltage, in order to supply power to operate an LED module and the LED light sources 202 of the LED tube lamp. A power supply, as described in connection with power supply 5, may be otherwise referred to as a power conversion module or circuit or a power module. A power conversion module or circuit, or power module, may supply or provide power from external signal(s), such as from an AC power line or from a ballast, to an LED module and the LED light sources 202. For example, a power supply 5 may refer to a circuit that converts ac line voltage to dc voltage and supplies power to the LED or LED module.

In some example embodiments, the outer surface of the wiring layer 2a or the dielectric layer 2b may be covered with a circuit protective layer made of an ink with function of resisting soldering and increasing reflectivity. Alternatively, in other example embodiments, the dielectric layer may be omitted and the wiring layer may be directly bonded to the inner circumferential surface of the lamp tube, and the outer surface of the wiring layer 2a may be coated with the circuit protective layer. Whether the wiring layer 2a has a one-layered, or two-layered structure, the circuit protective layer may be adopted. In some embodiments, the circuit protective layer is disposed only on one side/surface of the LED light strip 2, such as the surface having the LED light source 202. In some embodiments, the bendable circuit sheet is a one-layered structure made of just one wiring layer 2a, or a two-layered structure made of one wiring layer 2a and one dielectric layer 2b, and thus is more bendable or flexible

## 14

to curl when compared with the conventional three-layered flexible substrate (one dielectric layer sandwiched with two wiring layers). As a result, the bendable circuit sheet of the LED light strip 2 may be installed in a lamp tube with a customized shape or non-tubular shape, and fitly mounted to the inner surface of the lamp tube. A bendable circuit sheet closely mounted to the inner surface of the lamp tube is desirable in some cases. In addition, using fewer layers of the bendable circuit sheet improves the heat dissipation, lowering the material cost, and is more environmental friendly, and provides the opportunity to increase the flexible effect.

Nevertheless, the bendable circuit sheet is not limited to being one-layered or two-layered; in other embodiments, the bendable circuit sheet may include multiple layers of the wiring layers 2a and multiple layers of the dielectric layers 2b, in which the dielectric layers 2b and the wiring layers 2a are sequentially stacked in a staggered manner, respectively. These stacked layers may be between the outermost wiring layer 2a (with respect to the inner circumferential surface of the lamp tube), which has the LED light source 202 disposed thereon, and the inner circumferential surface of the lamp tube, and may be electrically connected to the power supply 5 (as shown in FIG. 1.) Moreover, in some embodiments, the length of the bendable circuit sheet (e.g., the length along a surface of the bendable circuit sheet from one end of the circuit sheet to a second end of the circuit sheet) (or an axial projection of the length of the bendable circuit sheet) is greater than the length of the lamp tube (or an axial projection of the length of the lamp tube), or at least greater than a central portion of the lamp tube between two transition regions (e.g., where the circumference of the lamp tube narrows) on either end. For example, the length following along the contours of one surface of the bendable circuit sheet (e.g., a top surface of the circuit sheet) may be longer than the length from one terminal end to an opposite terminal end of the lamp tube. Also, a length along a straight line that extends in the same direction as the direction in which the lamp tube extends, from a first end of the bendable circuit sheet to a second, opposite end of the bendable circuit sheet, may be longer than the length along the same straight line of the lamp tube.

Referring to FIG. 7, in one embodiment, an LED light strip 2 includes a bendable circuit sheet having in sequence a first wiring layer 2a, a dielectric layer 2b, and a second wiring layer 2c. In one example, the thickness of the second wiring layer 2c (e.g., in a direction in which the layers 2a through 2c are stacked) is greater than that of the first wiring layer 2a, and the length of the LED light strip 2 (or an axial projection of the length of the LED light strip 2) is greater than that of a lamp tube 1, or at least greater than a central portion of the lamp tube between two transition regions (e.g., where the circumference of the lamp tube narrows) on either end. The end region of the LED light strip 2 extending beyond the end portion of the lamp tube 1 without having a light source 202 disposed thereon is formed with two separate through holes 203 and 204 to respectively electrically communicate the first wiring layer 2a and the second wiring layer 2c. The through holes 203 and 204 are not in communication with each other to avoid short.

In this way, the greater thickness of the second wiring layer 2c allows the second wiring layer 2c to support the first wiring layer 2a and the dielectric layer 2b, and meanwhile allows the LED light strip 2 to be mounted onto the inner circumferential surface without being liable to shift or deform, and thus the yield rate of product can be improved. In addition, the first wiring layer 2a and the second wiring

US 9,841,174 B2

15

layer **2c** are in electrical communication such that the circuit layout of the first wiring later **2a** can be extended downward to the second wiring layer **2c** to reach the circuit layout of the entire LED light strip **2**. Moreover, since the circuit layout becomes two-layered, the area of each single layer and therefore the width of the LED light strip **2** can be reduced such that more LED light strips **2** can be put on a production line to increase productivity.

Furthermore, in some embodiments, the first wiring layer **2a** and the second wiring layer **2c** of the end region of the LED light strip **2** that extends beyond the end portion of the lamp tube **1** without disposition of the light source **202** can be used to accomplish the circuit layout of a power supply module so that the power supply module can be directly disposed on the bendable circuit sheet of the LED light strip **2**.

In a case where two ends of the LED light strip **2** are detached from the inner surface of the lamp tube **1** and where the LED light strip **2** is connected to the power supply **5** via wire-bonding, certain movements in subsequent transportation are likely to cause the bonded wires to break. Therefore, a desirable option for the connection between the LED light strip **2** and the power supply **5** (as shown in FIG. 1) could be soldering. Specifically, referring to FIG. 1, the ends of the LED light strip **2** including the bendable circuit sheet are arranged to pass over the strengthened transition region of a lamp tube, and to be directly solder bonded to an output terminal of the power supply **5**. This may improve product quality by avoiding using wires and/or wire bonding. As discussed herein, a transition region of the lamp tube refers to regions outside a central portion of the lamp tube and inside terminal ends of the lamp tube. For example, a central portion of the lamp tube may have a constant diameter, and each transition region between the central portion and a terminal end of the lamp tube may have a changing diameter (e.g., at least part of the transition region may become more narrow moving in a direction from the central portion to the terminal end of the lamp tube).

Referring to FIG. 3, an output terminal of a printed circuit board of the power supply **5** may have soldering pads "a" (as shown in FIG. 1 as well) provided with an amount of solder (e.g., tin solder) with a thickness sufficient to later form a solder joint "g" (or a solder ball "g"). Correspondingly, the ends of the LED light strip **2** may have soldering pads "b" (as shown in FIG. 1 as well). The soldering pads "a" on the output terminal of the printed circuit board of the power supply **5** are soldered to the soldering pads "b" on the LED light strip **2** via the tin solder on the soldering pads "a". The soldering pads "a" and the soldering pads "b" may be face to face during soldering such that the connection between the LED light strip **2** and the printed circuit board of the power supply **5** is the most firm. However, this kind of soldering typically includes a thermo-compression head pressing on the rear surface of the LED light strip **2** and heating the tin solder, i.e. the LED light strip **2** intervenes between the thermo-compression head and the tin solder, and therefore may cause reliability problems. In some embodiments, a through hole may be formed in each of the soldering pads "b" on the LED light strip **2** to allow the soldering pads "b" to overlay the soldering pads "a" without being face-to-face (e.g., both soldering pads "a" and soldering pads "b" can have exposed surfaces that face the same direction) and the thermo-compression head directly presses tin solders on the soldering pads "a" on surface of the printed circuit board of the power supply **5** when the soldering pads "a" and the soldering pads "b" are vertically aligned. This example provides a simple process for manufacturing.

16

Referring again to FIG. 3, two ends of the LED light strip **2** detached from the inner surface of the lamp tube **1** (as shown in FIG. 7) are formed as freely extending portions **21** (as shown in FIGS. 1 and 7 as well), while most of the LED light strip **2** is attached and secured to the inner surface of the lamp tube. One of the freely extending portions **21** has the soldering pads "b" as mentioned above. Upon assembling of the LED tube lamp, the freely extending end portions **21** along with the soldered connection of the printed circuit board of the power supply **5** and the LED light strip **2** would be coiled, curled up or deformed to be fittingly accommodated inside the lamp tube as shown in FIG. 1. When the bendable circuit sheet of the LED light strip **2** includes in sequence the first wiring layer **2a**, the dielectric layer **2b**, and the second wiring layer **2c** as shown in FIG. 7, the freely extending end portions **21**, which are the end regions of the LED light strip **2** extending beyond the lamp tube without disposition of the light sources **202**, can be used to accomplish the connection between the first wiring layer **2a** and the second wiring layer **2c** and arrange the circuit layout of the power supply **5**. As described above, the freely extending portions **21** may be different from a fixed portion of the LED light strip **2** in that the fixed portion may conform to the shape of the inner surface of the lamp tube and may be fixed thereto, while the freely extending portion **21** may have a shape that does not conform to the shape of the lamp tube. As shown in FIG. 1, the freely extending portion **21** may be bent away from the lamp tube. For example, there may be a space between an inner surface of the lamp tube and the freely extending portion **21**.

Referring to FIGS. 5 and 6, in another embodiment, the LED light strip and the power supply may be connected by utilizing a circuit board assembly **25** configured with a power supply module **250** instead of solder bonding as described previously. The circuit board assembly **25** has a long circuit sheet **251** and a short circuit board **253** that are adhered to each other with the short circuit board **253** being adjacent to the side edge of the long circuit sheet **251**. The short circuit board **253** may be provided with the power supply module **250** to form the power supply. The short circuit board **253** is stiffer or more rigid than the long circuit sheet **251** to be able to support the power supply module **250**.

The long circuit sheet **251** may be the bendable circuit sheet of the LED light strip **2** including a wiring layer **2a** as shown in FIG. 2. The wiring layer **2a** of the LED light strip **2** and the power supply module **250** may be electrically connected in various manners depending on the demand in practice. As shown in FIG. 5, the power supply module **250** and the long circuit sheet **251** having the wiring layer **2a** on surface are on the same side of the short circuit board **253** such that the power supply module **250** is directly connected to the long circuit sheet **251**. As shown in FIG. 6, alternatively, the power supply module **250** and the long circuit sheet **251** including the wiring layer **2a** on surface are on opposite sides of the short circuit board **253** such that the power supply module **250** is directly connected to the short circuit board **253** and indirectly connected to the wiring layer **2a** of the LED light strip **2** by way of the short circuit board **253**.

The power supply module **250** and power supply **5** described above may include various elements for providing power to the LED light strip **2**. For example, they may include power converters or other circuit elements for providing power to the LED light strip **2**.

FIG. 4A is a perspective view of an exemplary bendable circuit sheet **200** and a printed circuit board **420** of a power

US 9,841,174 B2

17

supply **400** soldered to each other. FIG. 4B to FIG. 4D are diagrams illustrating an exemplary soldering process of the bendable circuit sheet **200** and the printed circuit board **420** of the power supply **400**. In an embodiment, the bendable circuit sheet **200** and the freely extending end portion have the same structure. The freely extending end portion are the portions of two opposite ends of the bendable circuit sheet **200** and are utilized for being connected to the printed circuit board **420**. The bendable circuit sheet **200** and the power supply **400** are electrically connected to each other by soldering. The bendable circuit sheet **200** comprises a circuit layer **200a** and a circuit protection layer **200c** over a side of the circuit layer **200a**. Moreover, the bendable circuit sheet **200** comprises two opposite surfaces which are a first surface **2001** and a second surface **2002**. The first surface **2001** is the one on the circuit layer **200a** and away from the circuit protection layer **200c**. The second surface **2002** is the other one on the circuit protection layer **200c** and away from the circuit layer **200a**. Several LED light sources **202** are disposed on the first surface **2001** and are electrically connected to circuits of the circuit layer **200a**. The circuit protection layer **200c** is made, for example, by polyimide (PI) having less thermal conductivity but being beneficial to protect the circuits. The first surface **2001** of the bendable circuit sheet **200** comprises soldering pads "b" (or referred as first soldering pads). Soldering material "g" can be placed on the soldering pads "b". In one embodiment, the bendable circuit sheet **200** further comprises a notch "f". The notch "f" is disposed on an edge of the end of the bendable circuit sheet **200** soldered to the printed circuit board **420** of the power supply **400**. In some embodiments instead of a notch, a hole near the edge of the end of the bendable circuit sheet **200** may be used, which may thus provide additional contact material between the printed circuit board **420** and the bendable circuit sheet **200**, thereby providing a stronger connection. The printed circuit board **420** comprises a power circuit layer **420a** and soldering pads "a". Moreover, the printed circuit board **420** comprises two opposite surfaces which are a first surface (or a top surface) **421** and a second surface (or a bottom surface) **422**. The second surface **422** is the one on the power circuit layer **420a**. The soldering pads "a" are respectively disposed on the first surface **421** (those soldering pads "a" on the first surface **421** may be referred as second soldering pads) and the second surface **422** (those soldering pads "a" on the second surface **422** may be referred as third soldering pads). The soldering pads "a" on the first surface **421** are corresponding to those on the second surface **422**. Soldering material "g" can be placed on the soldering pad "a". In one embodiment, considering the stability of soldering and the optimization of automatic process, the bendable circuit sheet **200** is disposed below the printed circuit board **420** (the direction is referred to FIG. 4B). For example, the first surface **2001** of the bendable circuit sheet **200** is connected to the second surface **422** of the printed circuit board **420**. Also, as shown, the soldering material "g" can contact, cover, and be soldered to a top surface of the bendable circuit sheet **200** (e.g., first surface **2001**), end side surfaces of soldering pads "a," soldering pad "b," and power circuit layer **420a** formed at an edge of the printed circuit board **420**, and a top surface of soldering pad "a" at the top surface **421** of the printed circuit board **420**. In addition, the soldering material "g" can contact side surfaces of soldering pads "a," soldering pad "b," and power circuit layer **420a** formed at a hole in the printed circuit board **420** and/or at a hole or notch in bendable circuit sheet **200**. The soldering material may therefore form a bump-shaped portion covering portions of the bendable circuit

18

sheet **200** and the printed circuit board **420**, and a rod-shaped portion passing through the printed circuit board **420** and through a hole or notch in the bendable circuit sheet **200**. The two portions (e.g., bump-shaped portion and rod-shaped portion) may serve as a rivet, for maintaining a strong connection between the bendable circuit sheet **200** and the printed circuit board **420**.

As shown in FIG. 4C and FIG. 4D, in an exemplary soldering process of the bendable circuit sheet **200** and the printed circuit board **420**, the circuit protection layer **200c** of the bendable circuit sheet **200** is placed on a supporting table **42** (i.e., the second surface **2002** of the bendable circuit sheet **200** contacts the supporting table **42**) in advance of soldering. The soldering pads "a" on the second surface **422** of the printed circuit board **420** contact the soldering pads "b" on the first surface **2001** of the bendable circuit sheet **200**. And then a heating head **41** presses on a portion of soldering material "g" where the bendable circuit sheet **200** and the printed circuit board **420** are soldered to each other. When soldering, the soldering pads "b" on the first surface **2001** of the bendable circuit sheet **200** contact the soldering pads "a" on the second surface **422** of the printed circuit board **420**, and the soldering pads "a" on the first surface **421** of the printed circuit board **420** contact the soldering material "g," which is pressed on by the heating head **41**. Under the circumstance, the heat from the heating head **41** can transmit through the soldering pads "a" on the first surface **421** of the printed circuit board **420** and the soldering pads "a" on the second surface **422** of the printed circuit board **420** to the soldering pads "b" on the first surface **2001** of the bendable circuit sheet **200**. The transmission of the heat between the heating heads **41** and the soldering pads "a" and "b" won't be affected by the circuit protection layer **200c** which has relatively less thermal conductivity, since the circuit protection layer **200c** is not between the heating head **41** and the circuit layer **200a**. Consequently, the efficiency and stability regarding the connections and soldering process of the soldering pads "a" and "b" of the printed circuit board **420** and the bendable circuit sheet **200** can be improved.

As shown in the exemplary embodiment of FIG. 4C, the printed circuit board **420** and the bendable circuit sheet **200** are firmly connected to each other by the soldering material "g". Components between the virtual line M and the virtual line N of FIG. 4C from top to bottom are the soldering pads "a" on the first surface **421** of printed circuit board **420**, the power circuit layer **420a**, the soldering pads "a" on the second surface **422** of printed circuit board **420**, the soldering pads "b" on the first surface **2001** of bendable circuit sheet **200**, the circuit layer **200a** of the bendable circuit sheet **200**, and the circuit protection layer **200c** of the bendable circuit sheet **200**. The connection of the printed circuit board **420** and the bendable circuit sheet **200** are firm and stable. The soldering material "g" may extend higher than the soldering pads "a" on the first surface **421** of printed circuit board **420** and may fill in other spaces, as described above.

In other embodiments, an additional circuit protection layer (e.g., PI layer) can be disposed over the first surface **2001** of the circuit layer **200a**. For example, the circuit layer **200a** may be sandwiched between two circuit protection layers, and therefore the first surface **2001** of the circuit layer **200a** can be protected by the circuit protection layer. A part of the circuit layer **200a** (the part having the soldering pads "b") is exposed for being connected to the soldering pads "a" of the printed circuit board **420**. Other parts of the circuit layer **200a** are exposed by the additional circuit protection layer so they can connect to LED light sources **202**. Under these circumstances, a part of the bottom of each LED light

US 9,841,174 B2

19

source **202** contacts the circuit protection layer on the first surface **2001** of the circuit layer **200a**, and another part of the bottom of the LED light source **202** contacts the circuit layer **200a**.

According to the exemplary embodiments shown in FIG. 4A to FIG. 4D, the printed circuit board **420** comprises through holes "h" passing through the soldering pads "a". In an automatic soldering process, when the heating head **41** automatically presses the printed circuit board **420**, the soldering material "g" on the soldering pads "a" can be pushed into the through holes "h" by the heating head **41** accordingly. As a result, a soldered connection may be formed as shown in FIGS. 4C and 4D.

FIG. 8A is a block diagram of a system including an LED tube lamp including a power supply module according to certain embodiments. Referring to FIG. 8A, an alternating current (AC) power supply **508** is used to supply an AC supply signal, and may be an AC powerline with a voltage rating, for example, in 100-277V and a frequency rating, for example, of 50 Hz or 60 Hz. A lamp driving circuit **505** receives the AC supply signal from the AC power supply **508** and then converts it into an AC driving signal. The power supply module and power supply **508** described above may include various elements for providing power to the LED light strip **2**. For example, they may include power converters or other circuit elements for providing power to the LED light strip **2**. In some embodiments, the power supply **508** and the lamp driving circuit **505** are outside of the LED tube lamp. For example, the lamp driving circuit **505** may be part of a lamp socket or lamp holder into which the LED tube lamp is inserted. The lamp driving circuit **505** could be an electronic ballast and may be used to convert the signal of commercial electricity into high-frequency and high-voltage AC driving signal. The common types of electronic ballast, such as instant-start electronic ballast, program-start electronic ballast, and rapid-start electronic ballast, can be applied to the LED tube lamp. In some embodiments, the voltage of the AC driving signal is bigger than 300V and in some embodiments 400-700V with frequency being higher than 10 kHz and in some embodiments 20-50 kHz. An LED tube lamp **500** receives the AC driving signal from the lamp driving circuit **505** and is thus driven to emit light. In the present embodiment, the LED tube lamp **500** is in a driving environment in which it is power-supplied at its one end cap having two conductive pins **501** and **502**, which are used to receive the AC driving signal. The two pins **501** and **502** may be electrically coupled to, either directly or indirectly, the lamp driving circuit **505**.

In some embodiments, the lamp driving circuit **505** may be omitted and is therefore depicted by a dotted line. In certain embodiments, if the lamp driving circuit **505** is omitted, the AC power supply **508** is directly coupled to the pins **501** and **502**, which then receive the AC supply signal as the AC driving signal.

In some embodiments, the LED tube lamp may be power-supplied at its both end caps respectively having two conductive pins, which are coupled to the lamp driving circuit to concurrently receive the AC driving signal. However, in certain embodiments, referring to FIG. 8B, each end cap of the LED tube lamp **500** could have only one conductive pin for receiving the AC driving signal. For example, it is not required to have two conductive pins used in each end cap for the purpose of passing electricity through the both ends of the LED tube lamp. Compared to FIG. 8A, the conductive pins **501** and **502** in FIG. 8B are correspondingly configured at the both end caps of the LED tube lamp **500**, and the AC

20

power supply **508** and the lamp driving circuit **505** are the same as those mentioned above.

FIG. 8C is a block diagram of an LED lamp according to one embodiment. Referring to FIG. 8C, the power supply module of the LED lamp includes a rectifying circuit **510**, a filtering circuit **520**, and may further include some parts of an LED lighting module **530**. The rectifying circuit **510** is coupled to two pins **501** and **502** to receive and then rectify an external driving signal, so as to output a rectified signal at two rectifying output terminals **511** and **512**. In some embodiments, the external driving signal may be the AC driving signal or the AC supply signal described with reference to FIGS. 8A and 8B. In some embodiments, the external driving signal may be a direct current (DC) signal without altering the LED tube lamp. The filtering circuit **520** is coupled to the rectifying circuit for filtering the rectified signal to produce a filtered signal. For instance, the filtering circuit **520** is coupled to the rectifying circuit output terminals **511** and **512** to receive and then filter the rectified signal, so as to output a filtered signal at two filtering output terminals **521** and **522**. The LED lighting module **530** is coupled to the filtering circuit **520** to receive the filtered signal for emitting light. For instance, the LED lighting module **530** may include a circuit coupled to the filtering output terminals **521** and **522** to receive the filtered signal and thereby to drive an LED unit (not shown) in the LED lighting module **530** to emit light. Details of these operations are described below in accordance with certain embodiments.

Although there are two rectifying output terminals **511** and **512** and two filtering output terminals **521** and **522** in the embodiments of these FIGS., in practice the number of ports or terminals for coupling between the rectifying circuit **510**, the filtering circuit **520**, and the LED lighting module **530** may be one or more depending on the needs of signal transmission between the circuits or devices.

In addition, the power supply module of the LED lamp described in FIG. 8C, and embodiments of a power supply module of an LED lamp described below, may each be used in the LED tube lamp **500** in FIGS. 8A and 8B, and may instead be used in any other type of LED lighting structure having two conductive pins used to conduct power, such as LED light bulbs, personal area lights (PAL), plug-in LED lamps with different types of bases (such as types of PL-S, PL-D, PL-T, PL-L, etc.), etc. Further, the implementation for LED light bulbs may provide better effects on protecting from electric shock as combining this invention and the structures disclosed in PCT patent application WO2016045631.

FIG. 9 is a schematic diagram of a rectifying circuit according to an embodiment. Referring to FIG. 9, a rectifying circuit **610**, i.e. a bridge rectifier, includes four rectifying diodes **611**, **612**, **613**, and **614**, configured to full-wave rectify a received signal. The diode **611** has an anode connected to the output terminal **512**, and a cathode connected to the pin **502**. The diode **612** has an anode connected to the output terminal **512**, and a cathode connected to the pin **501**. The diode **613** has an anode connected to the pin **502**, and a cathode connected to the output terminal **511**. The diode **614** has an anode connected to the pin **501**, and a cathode connected to the output terminal **511**.

When the pins **501** and **502** receive an AC signal, the rectifying circuit **610** operates as follows. During the connected AC signal's positive half cycle, the AC signal is input through the pin **501**, the diode **614**, and the output terminal **511** in sequence, and later output through the output terminal **512**, the diode **611**, and the pin **502** in sequence. During the

## US 9,841,174 B2

## 21

connected AC signal's negative half cycle, the AC signal is input through the pin **502**, the diode **613**, and the output terminal **511** in sequence, and later output through the output terminal **512**, the diode **612**, and the pin **501** in sequence. Therefore, during the connected AC signal's full cycle, the positive pole of the rectified signal produced by the rectifying circuit **610** keeps at the output terminal **511**, and the negative pole of the rectified signal remains at the output terminal **512**. Accordingly, the rectified signal produced or output by the rectifying circuit **610** is a full-wave rectified signal.

When the pins **501** and **502** are coupled to a DC power supply to receive a DC signal, the rectifying circuit **610** operates as follows. When the pin **501** is coupled to the positive end of the DC power supply and the pin **502** to the negative end of the DC power supply, the DC signal is input through the pin **501**, the diode **614**, and the output terminal **511** in sequence, and later output through the output terminal **512**, the diode **611**, and the pin **502** in sequence. When the pin **501** is coupled to the negative end of the DC power supply and the pin **502** to the positive end of the DC power supply, the DC signal is input through the pin **502**, the diode **613**, and the output terminal **511** in sequence, and later output through the output terminal **512**, the diode **612**, and the pin **501** in sequence. Therefore, no matter what the electrical polarity of the DC signal is between the pins **501** and **502**, the positive pole of the rectified signal produced by the rectifying circuit **610** keeps at the output terminal **511**, and the negative pole of the rectified signal remains at the output terminal **512**.

Therefore, the rectifying circuit **610** in this embodiment can output or produce a proper rectified signal regardless of whether the received input signal is an AC or DC signal.

FIG. **10A** is a block diagram of the filtering circuit according to an embodiment. A rectifying circuit **510** is shown in FIG. **10A** for illustrating its connection with other components, without intending a filtering circuit **520** to include the rectifying circuit **510**. Referring to FIG. **10A**, the filtering circuit **520** includes a filtering unit **523** coupled to two rectifying output terminals **511** and **512** to receive and to filter out ripples of a rectified signal from the rectifying circuit **510**. Accordingly, the waveform of a filtered signal is smoother than that of the rectified signal. The filtering circuit **520** may further include another filtering unit **524** coupled between a rectifying circuit and a pin correspondingly, for example, between the rectifying circuit **510** and the pin **501**, the rectifying circuit **510** and the pin **502**, the rectifying circuit **540** and the pin **503**, and/or the rectifying circuit **540** and the pin **504**. The filtering unit **524** is used to filter a specific frequency, for example, to filter out a specific frequency of an external driving signal. In this embodiment, the filtering unit **524** is coupled between the rectifying circuit **510** and the pin **501**. The filtering circuit **520** may further include another filtering unit **525** coupled between one of the pins **501** and **502** and one of the diodes of the rectifying circuit **510**, or between one of the pins **503** and **504** and one of the diodes of the rectifying circuit **540** to reduce or filter out electromagnetic interference (EMI). In this embodiment, the filtering unit **525** is coupled between the pin **501** and one of diodes (not shown in FIG. **10A**) of the rectifying circuit **510**. Since the filtering units **524** and **525** may be present or omitted depending on actual circumstances of their uses, they are depicted by a dotted line in FIG. **10A**.

FIG. **10B** is a schematic diagram of the filtering unit according to an embodiment. Referring to FIG. **10B**, a filtering unit **623** includes a capacitor **625** having an end

## 22

coupled to the output terminal **511** and a filtering output terminal **521** and the other end thereof coupled to the output terminal **512** and a filtering output terminal **522**, and is configured to low-pass filter a rectified signal from the output terminals **511** and **512**, so as to filter out high-frequency components of the rectified signal and thereby output a filtered signal at the filtering output terminals **521** and **522**.

FIG. **10C** is a schematic diagram of the filtering unit according to an embodiment. Referring to FIG. **10C**, a filtering unit **723** includes a pi filter circuit including a capacitor **725**, an inductor **726**, and a capacitor **727**. As is well known, a pi filter circuit looks like the symbol  $\pi$  in its shape or structure. The capacitor **725** has an end connected to the output terminal **511** and coupled to the filtering output terminal **521** through the inductor **726**, and has another end connected to the output terminal **512** and the filtering output terminal **522**. The inductor **726** is coupled between output terminal **511** and the filtering output terminal **521**. The capacitor **727** has an end connected to the filtering output terminal **521** and coupled to the output terminal **511** through the inductor **726**, and has another end connected to the output terminal **512** and the filtering output terminal **522**.

As seen between the output terminals **511** and **512** and the filtering output terminals **521** and **522**, the filtering unit **723** compared to the filtering unit **623** in FIG. **10B** additionally has an inductor **726** and a capacitor **727**, which perform the function of low-pass filtering like the capacitor **725** does. Therefore, the filtering unit **723** in this embodiment compared to the filtering unit **623** in FIG. **10B** has a better ability to filter out high-frequency components to output a filtered signal with a smoother waveform.

The inductance values of the inductor **726** in the embodiments mentioned above are chosen in the range of, for example in some embodiments, about 10 nH to 10 mH. And the capacitance values of the capacitors **625**, **725**, and **727** in the embodiments stated above are chosen in the range of, for example in some embodiments, about 100 pF to 1  $\mu$ F.

FIG. **11A** is a schematic diagram of an LED module according to an embodiment. Referring to FIG. **11A**, an LED module **630** has an anode connected to a filtering output terminal **521**, a cathode connected to a filtering output terminal **522**, and includes at least one LED unit **632**, such as the light source mentioned above. When two or more LED units are included, they are connected in parallel. The anode of each LED unit **632** is connected to the anode of LED module **630** to couple with the filtering output terminal **521**, and the cathode of each LED unit **632** is connected to the cathode of LED module **630** to couple to the filtering output terminal **522**. Each LED unit **632** includes at least one LED **631**. When multiple LEDs **631** are included in an LED unit **632**, they are connected in series with the anode of the first LED **631** connected to the anode of this LED unit **632** and the cathode of the first LED **631** connected to the next or second LED **631**. And the anode of the last LED **631** in this LED unit **632** is connected to the cathode of a previous LED **631** and the cathode of the last LED **631** connected to the cathode of this LED unit **632**.

In some embodiments, the LED module **630** may produce a current detection signal **S531** reflecting the magnitude of current through the LED module **630** and being used for controlling or detecting the LED module **630**.

FIG. **11B** is a schematic diagram of an LED module according to an exemplary embodiment. Referring to FIG. **11B**, an LED module **630** has an anode connected to a filtering output terminal **521**, a cathode connected to a filtering output terminal **522**, and includes at least two LED

## US 9,841,174 B2

## 23

units **732** with the anode of each LED unit **732** connected to the anode of LED module **630** and the cathode of each LED unit **732** connected to the cathode of LED module **630**. Each LED unit **732** includes at least two LEDs **731** connected in the same way as those described in FIG. **11A**. For example, the anode of the first LED **731** in an LED unit **732** is connected to the anode of this LED unit **732**, the cathode of the first LED **731** is connected to the anode of the next or second LED **731**, and the cathode of the last LED **731** is connected to the cathode of this LED unit **732**. Further, LED units **732** in an LED module **630** are connected to each other in this embodiment. All of the n-th LEDs **731** in the related LED units **732** thereof are connected by their anodes and cathodes, such as those shown in FIG. **11B** but not limit to, where n is a positive integer. In this way, the LEDs in the LED module **630** of this embodiment are connected in the form of a mesh.

In some embodiments, the LED lighting module **530** in the above embodiments includes the LED module **630**, but doesn't include a driving circuit for the LED module **630**.

Also, the LED module **630** in this embodiment may produce a current detection signal **S531** reflecting the magnitude of current through the LED module **630** and being used for controlling or detecting the LED module **630**.

In some embodiments, the number of LEDs **731** included by an LED unit **732** is in the range of 15-25, and may be in some embodiments in the range of 18-22.

FIG. **11C** is a plan view of a circuit layout of the LED module according to an embodiment. Referring to FIG. **11C**, in this embodiment, multiple LEDs **831** are connected in the same way as described in FIG. **11B**, and three LED units are assumed in the LED module **630** and described as follows for illustration. A positive conductive line **834** and a negative conductive line **835** are to receive a driving signal for supplying power to the LEDs **831**. For example, the positive conductive line **834** may be coupled to the filtering output terminal **521** of the filtering circuit **520** described above, and the negative conductive line **835** coupled to the filtering output terminal **522** of the filtering circuit **520** to receive a filtered signal. For the convenience of illustration, all three of the n-th LEDs **831** in the three related LED units thereof are grouped as an LED set **833** in FIG. **11C**.

The positive conductive line **834** connects the three first LEDs **831** of the leftmost three related LED units thereof, that is, connects the anodes on the left sides of the three first LEDs **831** as shown in the leftmost LED set **833** of FIG. **11C**. The negative conductive line **835** connects the three last LEDs **831** of the rightmost three corresponding LED units thereof, that is, connects the cathodes on the right sides of the three last LEDs **831** as shown in the rightmost LED set **833** of FIG. **11C**. The cathodes of the three first LEDs **831**, the anodes of the three last LEDs **831**, and the anodes and cathodes of all the remaining LEDs **831** are connected by conductive lines or parts **839**.

For example, the anodes of the three LEDs **831** in the leftmost LED set **833** may be connected together by the positive conductive line **834**, and their cathodes may be connected together by a leftmost conductive part **839**. The anodes of the three LEDs **831** in the second, next-leftmost LED set **833** are also connected together by the leftmost conductive part **839**, whereas their cathodes are connected together by a second, next-leftmost conductive part **839**. Since the cathodes of the three LEDs **831** in the leftmost LED set **833** and the anodes of the three LEDs **831** in the second, next-leftmost LED set **833** are connected together by the same leftmost conductive part **839**, the cathode of the first LED **831** in each of the three LED units is connected to

## 24

the anode of the next or second LED **831**. As for the remaining LEDs **831** are also connected in the same way. Accordingly, all the LEDs **831** of the three LED units are connected to form the mesh as shown in FIG. **11B**.

In this embodiment, the length **836** of a portion of each conductive part **839** that connects to the anode of an LED **831** is smaller than the length **837** of another portion of each conductive part **839** that connects to the cathode of an LED **831**. This makes the area of the latter portion connecting to the cathode larger than that of the former portion connecting to the anode. Moreover, the length **837** may be smaller than a length **838** of a portion of each conductive part **839** that connects the cathode of an LED **831** and the anode of the next LED **831** in two adjacent LED sets **833**. This makes the area of the portion of each conductive part **839** that connects a cathode and an anode larger than the area of any other portion of each conductive part **839** that connects to only a cathode or an anode of an LED **831**. Due to the length differences and area differences, this layout structure improves heat dissipation of the LEDs **831**.

In some embodiments, the positive conductive line **834** includes a lengthwise portion **834a**, and the negative conductive line **835** includes a lengthwise portion **835a**, which are conducive to make the LED module have a positive "+" connective portion and a negative "-" connective portion at each of the two ends of the LED module, as shown in FIG. **11C**. Such a layout structure allows for coupling any of other circuits of the power supply module of the LED lamp, including e.g. the filtering circuit **520** and the rectifying circuits **510** and **540**, to the LED module through the positive connective portion and/or the negative connective portion at each or both ends of the LED lamp. Thus the layout structure increases the flexibility in arranging actual circuits in the LED lamp.

FIG. **11D** is a plan view of a circuit layout of the LED module according to another embodiment. Referring to FIG. **11D**, in this embodiment, multiple LEDs **931** are connected in the same way as described in FIG. **11A**, and three LED units each including 7 LEDs **931** are assumed in the LED module **630** and described as follows for illustration. A positive conductive line **934** and a negative conductive line **935** are to receive a driving signal for supplying power to the LEDs **931**. For example, the positive conductive line **934** may be coupled to the filtering output terminal **521** of the filtering circuit **520** described above, and the negative conductive line **935** is coupled to the filtering output terminal **522** of the filtering circuit **520**, so as to receive a filtered signal. For the convenience of illustration, all seven LEDs **931** of each of the three LED units are grouped as an LED set **932** in FIG. **11D**. Thus there are three LED sets **932** corresponding to the three LED units.

The positive conductive line **934** connects the anode on the left side of the first or leftmost LED **931** of each of the three LED sets **932**. The negative conductive line **935** connects the cathode on the right side of the last or rightmost LED **931** of each of the three LED sets **932**. In each LED set **932** of each two adjacent LEDs **931**, the LED **931** on the left has a cathode connected by a conductive part **939** to an anode of the LED **931** on the right. By such a layout, the LEDs **931** of each LED set **932** are connected in series.

In some embodiments, the conductive part **939** may be used to connect an anode and a cathode of two consecutive LEDs **931** respectively. The negative conductive line **935** connects the cathode of the last or rightmost LED **931** of each of the three LED sets **932**. And the positive conductive line **934** connects the anode of the first or leftmost LED **931** of each of the three LED sets **932**. Therefore, as shown in

## US 9,841,174 B2

25

FIG. 11D, the length of the conductive part **939** is larger than that of the portion of negative conductive line **935** connecting to a cathode, which length is then larger than that of the portion of positive conductive line **934** connecting to an anode. For example, the length **938** of the conductive part **939** may be larger than the length **937** of the portion of negative conductive line **935** connecting a cathode of an LED **931**, which length **937** is then larger than the length **936** of the portion of the positive conductive line **934** connecting an anode of an LED **931**. Such a layout structure improves heat dissipation of the LEDs **931** in LED module **630**.

The positive conductive line **934** may include a lengthwise portion **934a**, and the negative conductive line **935** may include a lengthwise portion **935a**, which are conducive to make the LED module have a positive "+" connective portion and a negative "-" connective portion at each of the two ends of the LED module, as shown in FIG. 11D. Such a layout structure allows for coupling any of other circuits of the power supply module of the LED lamp, including e.g. the filtering circuit **520** and the rectifying circuits **510** and **540**, to the LED module through the positive connective portion **934a** and/or the negative connective portion **935a** at each or both ends of the LED lamp. Thus the layout structure increases the flexibility in arranging actual circuits in the LED lamp.

Further, the circuit layouts as shown in FIGS. 11C and 11D may be implemented with a bendable circuit sheet or substrate, which may even be called flexible circuit board depending on its specific definition used. For example, the bendable circuit sheet may comprise one conductive layer where the positive conductive line **834**, the positive lengthwise portion **834a**, the negative conductive line **835**, the negative lengthwise portion **835a**, and the conductive parts **839** shown in FIG. 11C, and the positive conductive line **934**, the positive lengthwise portion **934a**, the negative conductive line **935**, the negative lengthwise portion **935a**, and the conductive parts **939** shown in FIG. 11D are formed by the method of etching.

FIG. 11E is a plan view of a circuit layout of the LED module according to another embodiment. The layout structures of the LED module in FIGS. 11E and 11C correspond to the same way of connecting the LEDs **831** as those shown in FIG. 11B, but the layout structure in FIG. 11E comprises two conductive layers instead of only one conductive layer for forming the circuit layout as shown in FIG. 11C. Referring to FIG. 11E, the main difference from the layout in FIG. 11C is that the positive conductive line **834** and the negative conductive line **835** have a lengthwise portion **834a** and a lengthwise portion **835a**, respectively, that are formed in a second conductive layer instead. The difference is elaborated as follows.

In certain embodiments, referring to FIG. 7 again at the same time, a bendable circuit sheet of the LED module includes a first conductive layer **2a** and a second conductive layer **2c** electrically insulated from each other by a dielectric layer **2b**. Of the two conductive layers, the positive conductive line **834**, the negative conductive line **835**, and the conductive parts **839** in FIG. 11E are formed in first conductive layer **2a** by the method of etching for electrically connecting the plurality of LED components **831** e.g. in a form of a mesh, whereas the positive lengthwise portion **834a** and the negative lengthwise portion **835a** are formed in second conductive layer **2c** by etching for electrically connecting (the filtering output terminal of) the filtering circuit. Further, the positive conductive line **834** and the negative conductive line **835** in the first conductive layer **2a** have via points **834b** and via points **835b**, respectively, for

26

connecting to second conductive layer **2c**. And the positive lengthwise portion **834a** and the negative lengthwise portion **835a** in second conductive layer **2c** have via points **834c** and via points **835c**, respectively. The via points **834b** are positioned corresponding to the via points **834c**, for connecting the positive conductive line **834** and the positive lengthwise portion **834a**. The via points **835b** are positioned corresponding to the via points **835c**, for connecting the negative conductive line **835** and the negative lengthwise portion **835a**. An exemplary desirable way of connecting the two conductive layers **2a** and **2c** is to form a hole connecting each via point **834b** and a corresponding via point **834c**, and to form a hole connecting each via point **835b** and a corresponding via point **835c**, with the holes extending through the two conductive layers **2a** and **2c** and the dielectric layer **2b** in-between. And the positive conductive line **834** and the positive lengthwise portion **834a** can be electrically connected by welding metallic part(s) through the connecting hole(s), and the negative conductive line **835** and the negative lengthwise portion **835a** can be electrically connected by welding metallic part(s) through the connecting hole(s).

Similarly, the layout structure of the LED module in FIG. 11D may alternatively have the positive lengthwise portion **934a** and the negative lengthwise portion **935a** disposed in a second conductive layer to constitute a two-layered layout structure.

The positive conductive lines (**834** or **934**) may be characterized as including two end terminals at opposite ends, a plurality of pads between the two end terminals and for contacting and/or supplying power to LEDs (e.g., anodes of LEDs), and a wire portion, which may be an elongated conductive line extending along a length of an LED light strip and electrically connecting the two end terminals to the plurality of pads. Similarly, the negative conductive lines (**835** or **935**) may be characterized as including two end terminals at opposite ends, a plurality of pads between the two end terminals and for contacting and/or supplying power to LEDs (e.g., cathodes of LEDs), and a wire portion, which may be an elongated conductive line extending along a length of an LED light strip and electrically connecting the two end terminals to the plurality of pads.

The circuit layouts may be implemented for one of the exemplary LED light strips described previously, for example, to serve as a circuit board or sheet for the LED light strip on which the LED light sources are disposed.

As described herein, an LED unit may refer to a single string of LEDs arranged in series, and an LED module may refer to a single LED unit, or a plurality of LED units connected to a same two nodes (e.g., arranged in parallel). For example, the LED light strip **2** described above may be an LED module and/or LED unit.

In some embodiments, the thickness of the second conductive layer of a two-layered bendable circuit sheet is, in some embodiments, larger than that of the first conductive layer in order to reduce the voltage drop or loss along each of the positive lengthwise portion and the negative lengthwise portion disposed in the second conductive layer. Compared to a one-layered bendable circuit sheet, since a positive lengthwise portion and a negative lengthwise portion are disposed in a second conductive layer in a two-layer bendable circuit sheet, the width (between two lengthwise sides) of the two-layered bendable circuit sheet is or can be reduced. On the same fixture or plate in a production process, the number of bendable circuit sheets each with a shorter width that can be laid together at most is larger than the number of bendable circuit sheets each with a longer



## US 9,841,174 B2

27

width that can be laid together at most. Thus adopting a bendable circuit sheet with a shorter width can increase the efficiency of production of the LED module. And reliability in the production process, such as the accuracy of welding position when welding (materials on) the LED components, can also be improved, because a two-layer bendable circuit sheet can better maintain its shape.

As a variant of the above embodiments, a type of an exemplary LED tube lamp is provided that may have at least some of the electronic components of its power supply module disposed on a light strip of the LED tube lamp. For example, the technique of printed electronic circuit (PEC) can be used to print, insert, or embed at least some of the electronic components onto the LED light strip (e.g., as opposed to being on a separate circuit board connected to the LED light strip).

In one embodiment, all electronic components of the power supply module are disposed on the light strip. The production process may include or proceed with the following steps: preparation of the circuit substrate (e.g. preparation of a flexible printed circuit board); ink jet printing of metallic nano-ink; ink jet printing of active and passive components (as of the power supply module); drying/sintering; ink jet printing of interlayer bumps; spraying of insulating ink; ink jet printing of metallic nano-ink; ink jet printing of active and passive components (to sequentially form the included layers); spraying of surface bond pad(s); and spraying of solder resist against LED components. The production process may be different, however, and still result in some or all electronic components of the power supply module being disposed directly on the LED light strip.

In certain embodiments, if all electronic components of the power supply module are disposed on the LED light strip, electrical connection between the terminal pins of the LED tube lamp and the light strip may be achieved by connecting the pins to conductive lines which are welded with ends of the light strip. In this case, another substrate for supporting the power supply module is not required, thereby allowing of an improved design or arrangement in the end cap(s) of the LED tube lamp. In some embodiments, (components of) the power supply module are disposed at two ends of the light strip, in order to significantly reduce the impact of heat generated from the power supply module's operations on the LED components. Since no substrate other than the light strip is used to support the power supply module in this case, the total amount of welding or soldering can be significantly reduced, improving the general reliability of the power supply module.

Another case is that some of all electronic components of the power supply module, such as some resistors and/or smaller size capacitors, are printed onto the light strip, and some bigger size components, such as some inductors and/or electrolytic capacitors, are disposed in the end cap(s). The production process of the light strip in this case may be the same as that described above. And in this case disposing some of all electronic components on the light strip is conducive to achieving a reasonable layout of the power supply module in the LED tube lamp, which may allow of an improved design in the end cap(s).

As a variant embodiment of the above, electronic components of the power supply module may be disposed on the LED light strip by a method of embedding or inserting, e.g. by embedding the components onto a bendable or flexible light strip. In some embodiments, this embedding may be realized by a method using copper-clad laminates (CCL) for forming a resistor or capacitor; a method using ink related to

28

silkscreen printing; or a method of ink jet printing to embed passive components, wherein an ink jet printer is used to directly print inks to constitute passive components and related functionalities to intended positions on the light strip. Then through treatment by ultraviolet (UV) light or drying/sintering, the light strip is formed where passive components are embedded. The electronic components embedded onto the light strip include for example resistors, capacitors, and inductors. In other embodiments, active components also may be embedded. Through embedding some components onto the light strip, a reasonable layout of the power supply module can be achieved to allow of an improved design in the end cap(s), because the surface area on a printed circuit board used for carrying components of the power supply module is reduced or smaller, and as a result the size, weight, and thickness of the resulting printed circuit board for carrying components of the power supply module is also smaller or reduced. Also in this situation since welding points on the printed circuit board for welding resistors and/or capacitors if they were not to be disposed on the light strip are no longer used, the reliability of the power supply module is improved, in view of the fact that these welding points are most liable to (cause or incur) faults, malfunctions, or failures. Further, the length of conductive lines needed for connecting components on the printed circuit board is therefore also reduced, which allows of a more compact layout of components on the printed circuit board and thus improving the functionalities of these components.

Next, methods to produce embedded capacitors and resistors are explained as follows.

Usually, methods for manufacturing embedded capacitors employ or involve a concept called distributed or planar capacitance. The manufacturing process may include the following step(s). On a substrate of a copper layer a very thin insulation layer is applied or pressed, which is then generally disposed between a pair of layers including a power conductive layer and a ground layer. The very thin insulation layer makes the distance between the power conductive layer and the ground layer very short. A capacitance resulting from this structure can also be realized by a conventional technique of a plated-through hole. Basically, this step is used to create this structure comprising a big parallel-plate capacitor on a circuit substrate.

Of products of high electrical capacity, certain types of products employ distributed capacitances, and other types of products employ separate embedded capacitances. Through putting or adding a high dielectric-constant material, such as barium titanate, into the insulation layer, the high electrical capacity is achieved.

A usual method for manufacturing embedded resistors employ conductive or resistive adhesive. This may include, for example, a resin to which conductive carbon or graphite is added, which may be used as an additive or filler. The additive resin is silkscreen printed to an object location, and is then after treatment laminated inside the circuit board. The resulting resistor is connected to other electronic components through plated-through holes or microvias. Another method is called Ohmega-Ply, by which a two metallic layer structure of a copper layer and a thin nickel alloy layer constitutes a layer resistor relative to a substrate. Then through etching the copper layer and nickel alloy layer, different types of nickel alloy resistors with copper terminals can be formed. These types of resistor are each laminated inside the circuit board.

In an embodiment, conductive wires/lines are directly printed in a linear layout on an inner surface of the LED glass lamp tube, with LED components directly attached on

## US 9,841,174 B2

29

the inner surface and electrically connected by the conductive wires. In some embodiments, the LED components in the form of chips are directly attached over the conductive wires on the inner surface, and connective points are at terminals of the wires for connecting the LED components and the power supply module. After being attached, the LED chips may have fluorescent powder applied or dropped thereon, for producing white light or light of other color by the operating LED tube lamp.

In some embodiments, luminous efficacy of the LED or LED component is 80 lm/W or above, and in some embodiments, it may be 120 lm/W or above. Certain more optimal embodiments may include a luminous efficacy of the LED or LED component of 160 lm/W or above. White light emitted by an LED component in the invention may be produced by mixing fluorescent powder with the monochromatic light emitted by a monochromatic LED chip. The white light in its spectrum has major wavelength ranges of 430-460 nm and 550-560 nm, or major wavelength ranges of 430-460 nm, 540-560 nm, and 620-640 nm.

FIG. 12A is a block diagram of a power supply module in an LED lamp according to an embodiment. As shown in FIG. 12A, the power supply module of the LED lamp includes a rectifying circuit 510, a filtering circuit 520, and may further include some parts of an LED lighting module 530. The LED lighting module 530 in this embodiment comprises a driving circuit 1530 and an LED module 630. The driving circuit 1530 comprises a DC-to-DC converter circuit, and is coupled to the filtering output terminals 521 and 522 to receive a filtered signal and then perform power conversion for converting the filtered signal into a driving signal at the driving output terminals 1521 and 1522. The LED module 630 is coupled to the driving output terminals 1521 and 1522 to receive the driving signal for emitting light. In some embodiments, the current of LED module 630 is stabilized at an objective current value. Descriptions of this LED module 630 are the same as those provided above with reference to FIGS. 11A-11E.

In some embodiments, the LED lighting module 530 shown in FIG. 8C may include the driving circuit 1530 and the LED module 630 as shown in FIG. 12A. Thus, the power supply module for the LED lamp in the present embodiment can be applied to the single-end power supply structure, such as LED light bulbs, personal area lights (PAL), and so forth.

FIG. 12B is a block diagram of the driving circuit according to an embodiment. Referring to FIG. 12B, a driving circuit includes a controller 1531, and a conversion circuit 1532 for power conversion based on a current source, for driving the LED module to emit light. The conversion circuit 1532 includes a switching circuit 1535 and an energy storage circuit 1538. And the conversion circuit 1532 is coupled to the filtering output terminals 521 and 522 to receive and then convert a filtered signal, under the control by the controller 1531, into a driving signal at the driving output terminals 1521 and 1522 for driving the LED module. Under the control by the controller 1531, the driving signal output by the conversion circuit 1532 comprises a steady current, making the LED module emitting steady light.

FIG. 12C is a schematic diagram of the driving circuit according to an embodiment. Referring to FIG. 12C, a driving circuit 1630 in this embodiment comprises a buck DC-to-DC converter circuit having a controller 1631 and a converter circuit. The converter circuit includes an inductor 1632, a diode 1633 for "freewheeling" of current, a capacitor 1634, and a switch 1635. The driving circuit 1630 is coupled to the filtering output terminals 521 and 522 to receive and then convert a filtered signal into a driving signal

30

for driving an LED module connected between the driving output terminals 1521 and 1522.

In this embodiment, the switch 1635 includes a metal-oxide-semiconductor field-effect transistor (MOSFET) and has a first terminal coupled to the anode of freewheeling diode 1633, a second terminal coupled to the filtering output terminal 522, and a control terminal coupled to the controller 1631 used for controlling current conduction or cutoff between the first and second terminals of switch 1635. The driving output terminal 1521 is connected to the filtering output terminal 521, and the driving output terminal 1522 is connected to an end of the inductor 1632, which has another end connected to the first terminal of switch 1635. The capacitor 1634 is coupled between the driving output terminals 1521 and 1522 to stabilize the voltage between the driving output terminals 1521 and 1522. The freewheeling diode 1633 has a cathode connected to the driving output terminal 1521.

Next, a description follows as to an exemplary operation of the driving circuit 1630.

The controller 1631 is configured for determining when to turn the switch 1635 on (in a conducting state) or off (in a cutoff state) according to a current detection signal S535 and/or a current detection signal S531. For example, in some embodiments, the controller 1631 is configured to control the duty cycle of switch 1635 being on and switch 1635 being off in order to adjust the size or magnitude of the driving signal. The current detection signal S535 represents the magnitude of current through the switch 1635. The current detection signal S531 represents the magnitude of current through the LED module coupled between the driving output terminals 1521 and 1522. The controller 1631 may control the duty cycle of the switch 1635 being on and off, based on, for example, a magnitude of a current detected based on current detection signal S531 or S535. As such, when the magnitude is above a threshold, the switch may be off (cutoff state) for more time, and when magnitude goes below the threshold, the switch may be on (conducting state) for more time. According to any of current detection signal S535 and current detection signal S531, the controller 1631 can obtain information on the magnitude of power converted by the converter circuit. When the switch 1635 is switched on, a current of a filtered signal is input through the filtering output terminal 521, and then flows through the capacitor 1634, the driving output terminal 1521, the LED module, the inductor 1632, and the switch 1635, and then flows out from the filtering output terminal 522. During this flowing of current, the capacitor 1634 and the inductor 1632 are performing storing of energy. On the other hand, when the switch 1635 is switched off, the capacitor 1634 and the inductor 1632 perform releasing of stored energy by a current flowing from the freewheeling diode 1633 to the driving output terminal 1521 to make the LED module continuing to emit light.

In some embodiments, the capacitor 1634 is an optional element, so it can be omitted and is thus depicted in a dotted line in FIG. 12C. In some application environments, the natural characteristic of an inductor to oppose instantaneous change in electric current passing through the inductor may be used to achieve the effect of stabilizing the current through the LED module, thus omitting the capacitor 1634.

As described above, because the driving circuit 1630 is configured for determining when to turn a switch 1635 on (in a conducting state) or off (in a cutoff state) according to a current detection signal S535 and/or a current detection signal S531, the driving circuit 1630 can maintain a stable current flow through the LED module. Therefore, the color

US 9,841,174 B2

31

temperature may not change with current to some LED module, such as white, red, blue, green LED modules. For example, an LED can retain the same color temperature under different illumination conditions. In some embodiments, because the inductor 1632 playing the role of the energy-storing circuit releases the stored power when the switch 1635 cuts off, the voltage/current flowing through the LED module remains above a predetermined voltage/current level so that the LED module may continue to emit light maintaining the same color temperature. In this way, when the switch 1635 conducts again, the voltage/current flowing through the LED module does not need to be adjusted to go from a minimum value to a maximum value. Accordingly, the LED module lighting with flickering can be avoided, the entire illumination can be improved, the lowest conducting period can be smaller, and the driving frequency can be higher.

FIG. 12D is a schematic diagram of the driving circuit according to an embodiment. Referring to FIG. 12D, a driving circuit 1730 in this embodiment comprises a boost DC-to-DC converter circuit having a controller 1731 and a converter circuit. The converter circuit includes an inductor 1732, a diode 1733 for "freewheeling" of current, a capacitor 1734, and a switch 1735. The driving circuit 1730 is configured to receive and then convert a filtered signal from the filtering output terminals 521 and 522 into a driving signal for driving an LED module coupled between the driving output terminals 1521 and 1522.

The inductor 1732 has an end connected to the filtering output terminal 521, and another end connected to the anode of freewheeling diode 1733 and a first terminal of the switch 1735, which has a second terminal connected to the filtering output terminal 522 and the driving output terminal 1522. The freewheeling diode 1733 has a cathode connected to the driving output terminal 1521. And the capacitor 1734 is coupled between the driving output terminals 1521 and 1522.

The controller 1731 is coupled to a control terminal of switch 1735, and is configured for determining when to turn the switch 1735 on (in a conducting state) or off (in a cutoff state), according to a current detection signal S535 and/or a current detection signal S531. When the switch 1735 is switched on, a current of a filtered signal is input through the filtering output terminal 521, and then flows through the inductor 1732 and the switch 1735, and then flows out from the filtering output terminal 522. During this flowing of current, the current through the inductor 1732 increases with time, with the inductor 1732 being in a state of storing energy, while the capacitor 1734 enters a state of releasing energy, making the LED module continuing to emit light. On the other hand, when the switch 1735 is switched off, the inductor 1732 enters a state of releasing energy as the current through the inductor 1732 decreases with time. In this state, the current through the inductor 1732 then flows through the freewheeling diode 1733, the capacitor 1734, and the LED module, while the capacitor 1734 enters a state of storing energy.

In some embodiments the capacitor 1734 is an optional element, so it can be omitted and is thus depicted in a dotted line in FIG. 12D. When the capacitor 1734 is omitted and the switch 1735 is switched on, the current of inductor 1732 does not flow through the LED module, making the LED module not emit light; but when the switch 1735 is switched off, the current of inductor 1732 flows through the freewheeling diode 1733 to reach the LED module, making the LED module emit light. Therefore, by controlling the time that the LED module emits light, and the magnitude of

32

current through the LED module, the average luminance of the LED module can be stabilized to be above a defined value, thus also achieving the effect of emitting a steady light.

As described above, because the controller 1731 included in the driving circuit 1730 is coupled to the control terminal of switch 1735, and is configured for determining when to turn a switch 1735 on (in a conducting state) or off (in a cutoff state), according to a current detection signal S535 and/or a current detection signal S531, the driving circuit 1730 can maintain a stable current flow through the LED module. Therefore, the color temperature may not change with current to some LED modules, such as white, red, blue, or green LED modules. For example, an LED can retain the same color temperature under different illumination conditions. In some embodiments, because the inductor 1732 playing the role of the energy-storing circuit releases the stored power when the switch 1735 cuts off, the voltage/current flowing through the LED module remains above a predetermined voltage/current level so that the LED module may continue to emit light maintaining the same color temperature. In this way, when the switch 1735 conducts again, the voltage/current flowing through the LED module does not need to be adjusted to go from a minimum value to a maximum value. Accordingly, the LED module lighting with flickering can be avoided, the entire illumination can be improved, the lowest conducting period can be smaller, and the driving frequency can be higher.

FIG. 12E is a schematic diagram of the driving circuit according to an exemplary embodiment. Referring to FIG. 12E, a driving circuit 1830 in this embodiment comprises a buck DC-to-DC converter circuit having a controller 1831 and a converter circuit. The converter circuit includes an inductor 1832, a diode 1833 for "freewheeling" of current, a capacitor 1834, and a switch 1835. The driving circuit 1830 is coupled to the filtering output terminals 521 and 522 to receive and then convert a filtered signal into a driving signal for driving an LED module connected between the driving output terminals 1521 and 1522.

The switch 1835 has a first terminal coupled to the filtering output terminal 521, a second terminal coupled to the cathode of freewheeling diode 1833, and a control terminal coupled to the controller 1831 to receive a control signal from the controller 1831 for controlling current conduction or cutoff between the first and second terminals of the switch 1835. The anode of freewheeling diode 1833 is connected to the filtering output terminal 522 and the driving output terminal 1522. The inductor 1832 has an end connected to the second terminal of switch 1835, and another end connected to the driving output terminal 1521. The capacitor 1834 is coupled between the driving output terminals 1521 and 1522 to stabilize the voltage between the driving output terminals 1521 and 1522.

The controller 1831 is configured for controlling when to turn the switch 1835 on (in a conducting state) or off (in a cutoff state) according to a current detection signal S535 and/or a current detection signal S531. When the switch 1835 is switched on, a current of a filtered signal is input through the filtering output terminal 521, and then flows through the switch 1835, the inductor 1832, and the driving output terminals 1521 and 1522, and then flows out from the filtering output terminal 522. During this flowing of current, the current through the inductor 1832 and the voltage of the capacitor 1834 both increase with time, so the inductor 1832 and the capacitor 1834 are in a state of storing energy. On the other hand, when the switch 1835 is switched off, the inductor 1832 is in a state of releasing energy and thus the

US 9,841,174 B2

33

current through it decreases with time. In this case, the current through the inductor **1832** circulates through the driving output terminals **1521** and **1522**, the freewheeling diode **1833**, and back to the inductor **1832**.

In some embodiments the capacitor **1834** is an optional element, so it can be omitted and is thus depicted in a dotted line in FIG. **12E**. When the capacitor **1834** is omitted, no matter whether the switch **1835** is turned on or off, the current through the inductor **1832** will flow through the driving output terminals **1521** and **1522** to drive the LED module to continue emitting light.

As described above, because the controller **1831** included in the driving circuit **1830** is configured for controlling when to turn a switch **1835** on (in a conducting state) or off (in a cutoff state) according to a current detection signal **S535** and/or a current detection signal **S531**, the driving circuit **1730** can maintain a stable current flow through the LED module. Therefore, the color temperature may not change with current to some LED modules, such as white, red, blue, or green LED modules. For example, an LED can retain the same color temperature under different illumination conditions. In some embodiments, because the inductor **1832** playing the role of the energy-storing circuit releases the stored power when the switch **1835** cuts off, the voltage/current flowing through the LED module remains above a predetermined voltage/current level so that the LED module may continue to emit light maintaining the same color temperature. In this way, when the switch **1835** conducts again, the voltage/current flowing through the LED module does not need to be adjusted to go from a minimum value to a maximum value. Accordingly, the LED module lighting with flickering can be avoided, the entire illumination can be improved, the lowest conducting period can be smaller, and the driving frequency can be higher.

FIG. **12F** is a schematic diagram of the driving circuit according to an exemplary embodiment. Referring to FIG. **12F**, a driving circuit **1930** in this embodiment comprises a buck DC-to-DC converter circuit having a controller **1931** and a converter circuit. The converter circuit includes an inductor **1932**, a diode **1933** for "freewheeling" of current, a capacitor **1934**, and a switch **1935**. The driving circuit **1930** is coupled to the filtering output terminals **521** and **522** to receive and then convert a filtered signal into a driving signal for driving an LED module connected between the driving output terminals **1521** and **1522**.

The inductor **1932** has an end connected to the filtering output terminal **521** and the driving output terminal **1522**, and another end connected to a first end of the switch **1935**. The switch **1935** has a second end connected to the filtering output terminal **522**, and a control terminal connected to controller **1931** to receive a control signal from controller **1931** for controlling current conduction or cutoff of the switch **1935**. The freewheeling diode **1933** has an anode coupled to a node connecting the inductor **1932** and the switch **1935**, and a cathode coupled to the driving output terminal **1521**. The capacitor **1934** is coupled to the driving output terminals **1521** and **1522** to stabilize the driving of the LED module coupled between the driving output terminals **1521** and **1522**.

The controller **1931** is configured for controlling when to turn the switch **1935** on (in a conducting state) or off (in a cutoff state) according to a current detection signal **S531** and/or a current detection signal **S535**. When the switch **1935** is turned on, a current is input through the filtering output terminal **521**, and then flows through the inductor **1932** and the switch **1935**, and then flows out from the filtering output terminal **522**. During this flowing of current,

34

the current through the inductor **1932** increases with time, so the inductor **1932** is in a state of storing energy; but the voltage of the capacitor **1934** decreases with time, so the capacitor **1934** is in a state of releasing energy to keep the LED module continuing to emit light. On the other hand, when the switch **1935** is turned off, the inductor **1932** is in a state of releasing energy and its current decreases with time. In this case, the current through the inductor **1932** circulates through the freewheeling diode **1933**, the driving output terminals **1521** and **1522**, and back to the inductor **1932**. During this circulation, the capacitor **1934** is in a state of storing energy and its voltage increases with time.

In some embodiments the capacitor **1934** is an optional element, so it can be omitted and is thus depicted in a dotted line in FIG. **12F**. When the capacitor **1934** is omitted and the switch **1935** is turned on, the current through the inductor **1932** doesn't flow through the driving output terminals **1521** and **1522**, thereby making the LED module not emit light. On the other hand, when the switch **1935** is turned off, the current through the inductor **1932** flows through the freewheeling diode **1933** and then the LED module to make the LED module emit light. Therefore, by controlling the time that the LED module emits light, and the magnitude of current through the LED module, the average luminance of the LED module can be stabilized to be above a defined value, thus also achieving the effect of emitting a steady light.

As described above, because the controller **1931** included in the driving circuit **1930** is configured for controlling when to turn a switch **1935** on (in a conducting state) or off (in a cutoff state) according to a current detection signal **S535** and/or a current detection signal **S531**, the driving circuit **1930** can maintain a stable current flow through the LED module. Therefore, the color temperature may not change with current to some LED modules, such as white, red, blue, or green LED modules. For example, an LED can retain the same color temperature under different illumination conditions. In some embodiments, because the inductor **1932** playing the role of the energy-storing circuit releases the stored power when the switch **1935** cuts off, the voltage/current flowing through the LED module remains above a predetermined voltage/current level so that the LED module may continue to emit light maintaining the same color temperature. In this way, when the switch **1935** conducts again, the voltage/current flowing through the LED module does not need to be adjusted to go from a minimum value to a maximum value. Accordingly, the LED module lighting with flickering can be avoided, the entire illumination can be improved, the lowest conducting period can be smaller, and the driving frequency can be higher.

With reference to FIGS. **5** and **6**, a short circuit board **253** includes a first short circuit substrate and a second short circuit substrate respectively connected to two terminal portions of a long circuit sheet **251**, and electronic components of the power supply module are respectively disposed on the first short circuit substrate and the second short circuit substrate. The first short circuit substrate and the second short circuit substrate may have roughly the same length, or different lengths. In general, the first short circuit substrate (i.e. the right circuit substrate of short circuit board **253** in FIG. **5** and the left circuit substrate of short circuit board **253** in FIG. **6**) has a length that is about 30%-80% of the length of the second short circuit substrate (i.e. the left circuit substrate of short circuit board **253** in FIG. **5** and the right circuit substrate of short circuit board **253** in FIG. **6**). In some embodiments the length of the first short circuit substrate is about  $\frac{1}{3}$ - $\frac{2}{3}$  of the length of the second short

## US 9,841,174 B2

35

circuit substrate. For example, in one embodiment, the length of the first short circuit substrate may be about half the length of the second short circuit substrate. The length of the second short circuit substrate may be, for example in the range of about 15 mm to about 65 mm, depending on actual application occasions. In certain embodiments, the first short circuit substrate is disposed in an end cap at an end of the LED tube lamp, and the second short circuit substrate is disposed in another end cap at the opposite end of the LED tube lamp.

For example, capacitors of the driving circuit, such as the capacitors 1634, 1734, 1834, and 1934 in FIGS. 12C-12F, in practical use may include two or more capacitors connected in parallel. Some or all capacitors of the driving circuit in the power supply module may be arranged on the first short circuit substrate of short circuit board 253, while other components such as the rectifying circuit, filtering circuit, inductor(s) of the driving circuit, controller(s), switch(es), diodes, etc. are arranged on the second short circuit substrate of short circuit board 253. Since the inductors, controllers, switches, etc. are electronic components with higher temperature, arranging some or all capacitors on a circuit substrate separate or away from the circuit substrate(s) of high-temperature components helps prevent the working life of capacitors (especially electrolytic capacitors) from being negatively affected by the high-temperature components, thus improving the reliability of the capacitors. Further, the physical separation between the capacitors and both the rectifying circuit and filtering circuit also contributes to reducing the problem of EMI.

In certain exemplary embodiments, the conversion efficiency of the driving circuits is above 80%. In some embodiments, the conversion efficiency of the driving circuits is above 90%. In still other embodiments, the conversion efficiency of the driving circuits is above 92%. The illumination efficiency of the LED lamps is above 120 lm/W. In some embodiments, the illumination efficiency of the LED lamps is above 160 lm/W. The illumination efficiency including the combination of the driving circuits and the LED modules is above  $120 \text{ lm/W} * 90\% = 108 \text{ lm/W}$ . In some embodiments, the illumination efficiency including the combination of the driving circuits and the LED modules is above  $160 \text{ lm/W} * 92\% = 147.21 \text{ lm/W}$ .

In some embodiments, the transmittance of the diffusion film in the LED tube lamp is above 85%. As a result, in certain embodiments, the illumination efficiency of the LED lamps is above  $108 \text{ lm/W} * 85\% = 91.8 \text{ lm/W}$ . In some embodiments, the illumination efficiency of the LED lamps is above  $147.21 \text{ lm/W} * 85\% = 125.12 \text{ lm/W}$ .

FIG. 13A is a block diagram of a power supply module in an LED tube lamp according to an exemplary embodiment. Compared to that shown in FIG. 8C, the present embodiment comprises a rectifying circuit 510, a filtering circuit 520, and a driving circuit 1530, and further comprises an over voltage protection (OVP) circuit 1570. In this embodiment, a driving circuit 1530 and an LED module 630 compose the LED lighting module 530. The OVP circuit 1570 is coupled to the filtering output terminals 521 and 522 for detecting the filtered signal. The OVP circuit 1570 clamps the logic level of the filtered signal when determining the logic level thereof higher than a defined OVP value. Hence, the OVP circuit 1570 protects the LED lighting module 530 from damage due to an OVP condition.

FIG. 13B is a schematic diagram of an overvoltage protection (OVP) circuit according to an exemplary embodiment. An OVP circuit 1670 comprises a voltage clamping diode 1671, such as zener diode, coupled to the filtering

36

output terminals 521 and 522. The voltage clamping diode 1671 is conducted to clamp a voltage difference at a breakdown voltage when the voltage difference of the filtering output terminals 521 and 522 (i.e., the logic level of the filtered signal) reaches the breakdown voltage. In some embodiments, the breakdown voltage may be in a range of about 40 V to about 100 V. In certain embodiments, the breakdown voltage may be in a range of about 55 V to about 75V.

FIG. 14A is a block diagram of a power supply module in an LED tube lamp according to an exemplary embodiment. Compared to that shown in FIG. 8C, the present embodiment comprises a rectifying circuit 510, a filtering circuit 520, and a driving circuit 1530, and further comprises an auxiliary power module 2510. The auxiliary power module 2510 is coupled between the filtering output terminals 521 and 522. The auxiliary power module 2510 detects the filtered signal in the filtering output terminals 521 and 522, and determines whether providing an auxiliary power to the filtering output terminals 521 and 522 based on the detected result. When the supply of the filtered signal is stopped or a logic level thereof is insufficient, i.e., when a drive voltage for the LED module is below a defined voltage, the auxiliary power module provides auxiliary power to keep the LED lighting module 530 continuing to emit light. The defined voltage is determined according to an auxiliary power voltage of the auxiliary power module 2510.

FIG. 14B is a block diagram of a power supply module in an LED tube lamp according to an exemplary embodiment. Compared to that shown in FIG. 14A, the present embodiment comprises a rectifying circuit 510, a filtering circuit 520, and may further include some parts of an LED lighting module 530, and an auxiliary power module 2510, and the LED lighting module 530 further comprises a driving circuit 1530 and an LED module 630. The auxiliary power module 2510 is coupled between the driving output terminals 1521 and 1522. The auxiliary power module 2510 detects the driving signal in the driving output terminals 1521 and 1522, and determines whether to provide an auxiliary power to the driving output terminals 1521 and 1522 based on the detected result. When the driving signal is no longer being supplied or a logic level thereof is insufficient, the auxiliary power module 2510 provides the auxiliary power to keep the LED module 630 continuously light.

FIG. 14C is a schematic diagram of an auxiliary power module according to an embodiment. The auxiliary power module 2610 comprises an energy storage unit 2613 and a voltage detection circuit 2614. The auxiliary power module further comprises an auxiliary power positive terminal 2611 and an auxiliary power negative terminal 2612 for being respectively coupled to the filtering output terminals 521 and 522 or the driving output terminals 1521 and 1522. The voltage detection circuit 2614 detects a logic level of a signal at the auxiliary power positive terminal 2611 and the auxiliary power negative terminal 2612 to determine whether releasing outward the power of the energy storage unit 2613 through the auxiliary power positive terminal 2611 and the auxiliary power negative terminal 2612.

In some embodiments, the energy storage unit 2613 is a battery or a supercapacitor. When a voltage difference of the auxiliary power positive terminal 2611 and the auxiliary power negative terminal 2612 (the drive voltage for the LED module) is higher than the auxiliary power voltage of the energy storage unit 2613, the voltage detection circuit 2614 charges the energy storage unit 2613 by the signal in the auxiliary power positive terminal 2611 and the auxiliary power negative terminal 2612. When the drive voltage is

US 9,841,174 B2

37

lower than the auxiliary power voltage, the energy storage unit **2613** releases the stored energy outward through the auxiliary power positive terminal **2611** and the auxiliary power negative terminal **2612**.

The voltage detection circuit **2614** comprises a diode **2615**, a bipolar junction transistor (BJT) **2616** and a resistor **2617**. A positive end of the diode **2615** is coupled to a positive end of the energy storage unit **2613** and a negative end of the diode **2615** is coupled to the auxiliary power positive terminal **2611**. The negative end of the energy storage unit **2613** is coupled to the auxiliary power negative terminal **2612**. A collector of the BJT **2616** is coupled to the auxiliary power positive terminal **2611**, and an emitter thereof is coupled to the positive end of the energy storage unit **2613**. One end of the resistor **2617** is coupled to the auxiliary power positive terminal **2611** and the other end is coupled to a base of the BJT **2616**. When the collector of the BJT **2616** is a cut-in voltage higher than the emitter thereof, the resistor **2617** conducts the BJT **2616**. When the power source provides power to the LED tube lamp normally, the energy storage unit **2613** is charged by the filtered signal through the filtering output terminals **521** and **522** and the conducted BJT **2616** or by the driving signal through the driving output terminals **1521** and **1522** and the conducted BJT **2616** until that the collector-emitter voltage of the BJT **2616** is lower than or equal to the cut-in voltage. When the filtered signal or the driving signal is no longer being supplied or the logic level thereof is insufficient, the energy storage unit **2613** provides power through the diode **2615** to keep the LED lighting module **530** or the LED module **630** continuously light.

In some embodiments, the maximum voltage of the charged energy storage unit **2613** is at least one cut-in voltage of the BJT **2616** lower than the voltage difference applied between the auxiliary power positive terminal **2611** and the auxiliary power negative terminal **2612**. The voltage difference provided between the auxiliary power positive terminal **2611** and the auxiliary power negative terminal **2612** is a turn-on voltage of the diode **2615** lower than the voltage of the energy storage unit **2613**. Hence, when the auxiliary power module **2610** provides power, the voltage applied at the LED module **630** is lower (about the sum of the cut-in voltage of the BJT **2616** and the turn-on voltage of the diode **2615**). In the embodiment shown in the FIG. **14B**, the brightness of the LED module **630** is reduced when the auxiliary power module supplies power thereto. Thereby, when the auxiliary power module is applied to an emergency lighting system or a constant lighting system, the user realizes the main power supply, such as commercial power, is abnormal and then performs necessary precautions therefor.

Referring to FIG. **15A**, a block diagram of an LED tube lamp including a power supply module in accordance with certain embodiments is illustrated. Compared to the LED lamp shown in FIG. **8C**, the LED tube lamp of FIG. **15A** includes a rectifying circuit **510**, a filtering circuit **520**, and an LED lighting module **530**, and further includes an installation detection module **2520**. The installation detection module **2520** is coupled to the rectifying circuit **510** via an installation detection terminal **2521** and is coupled to the filtering circuit **520** via an installation detection terminal **2522**. The installation detection module **2520** detects the signal passing through the installation detection terminals **2521** and **2522** and determines whether to cut off an LED driving signal (e.g., an external driving signal) passing through the LED tube lamp based on the detected result. The installation detection module **2520** includes circuitry con-

38

figured to perform the steps of detecting the signal passing through the installation detection terminals **2521** and **2522** and determining whether to cut off an LED driving signal, and thus may be referred to as an installation detection circuit, or more generally as a detection circuit or cut-off circuit. When an LED tube lamp is not yet installed on a lamp socket or holder, or in some cases if it is not installed properly or is only partly installed (e.g., one side is connected to a lamp socket, but not the other side yet), the installation detection module **2520** detects a smaller current compared to a predetermined current (or current value) and determines the signal is passing through a high impedance through the installation detection terminals **2521** and **2522**. In this case, in certain embodiments, the installation detection circuit **2520** is in a cut-off state to make the LED tube lamp stop working. Otherwise, the installation detection module **2520** determines that the LED tube lamp has already been installed on the lamp socket or holder (e.g., when the installation detection module **2520** detects a current equal to or larger than a predetermined current and determines the signal is passing through a low impedance through the installation detection terminals **2521** and **2522**), and maintains conductive state to make the LED tube lamp working normally.

For example, in some embodiments, when a current passing through the installation detection terminals **2521** and **2522** is greater than or equal to a specific, defined installation current (or a current value), which may indicate that the current supplied to the LED lighting module **530** is greater than or equal to a specific, defined operating current, the installation detection module **2520** is conductive to make the LED tube lamp operate in a conductive state. For example, a current greater than or equal to the specific current value may indicate that the LED tube lamp has correctly been installed in the lamp socket or holder. When the current passing through the installation detection terminals **2521** and **2522** is smaller than the specific, defined installation current (or the current value), which may indicate that the current supplied to the LED lighting module **530** is less than a specific, defined operating current, the installation detection module **2520** cuts off current to make the LED tube lamp enter in a non-conducting state based on determining that the LED tube lamp has been not installed in, or does not properly connect to, the lamp socket or holder. In certain embodiments, the installation detection module **2520** determines conducting or cutting off based on the impedance detection to make the LED tube lamp operate in a conducting state or enter non-conducting state. The LED tube lamp operating in a conducting state may refer to the LED tube lamp including a sufficient current passing through the LED module to cause the LED light sources to emit light. The LED tube lamp operating in a cut-off state may refer to the LED tube lamp including an insufficient current or no current passing through the LED module so that the LED light sources do not emit light. Accordingly, the occurrence of electric shock caused by touching the conductive part of the LED tube lamp which is incorrectly installed on the lamp socket or holder can be efficiently avoided.

Referring to FIG. **15B**, a block diagram of an installation detection module in accordance with certain embodiments is illustrated. The installation detection module includes a switch circuit **2580**, a detection pulse generating module **2540**, a detection result latching circuit **2560**, and a detection determining circuit **2570**. Certain of these circuits or modules may be referred to as first, second, third, etc., circuits as a naming convention to differentiate them from each other.

## US 9,841,174 B2

39

The detection determining circuit 2570 is coupled to and detects the signal between the installation detection terminals 2521 (through a switch circuit coupling terminal 2581 and the switch circuit 2580) and 2522. The detection determining circuit 2570 is also coupled to the detection result latching circuit 2560 via a detection result terminal 2571 to transmit the detection result signal to the detection result latching circuit 2560. The detection determining circuit 2570 may be configured to detect a current passing through terminals 2521 and 2522 (e.g., to detect whether the current is above or below a specific current value).

The detection pulse generating module 2540 is coupled to the detection result latching circuit 2560 via a pulse signal output terminal 2541, and generates a pulse signal to inform the detection result latching circuit 2560 of a time point for latching (storing) the detection result. For example, the detection pulse generating module 2540 may be a circuit configured to generate a signal that causes a latching circuit, such as the detection result latching circuit 2560 to enter and remain in a state that corresponds to one of a conducting state or a cut-off state for the LED tube lamp. The detection result latching circuit 2560 stores the detection result according to the detection result signal (or detection result signal and pulse signal), and transmits or provides the detection result to the switch circuit 2580 coupled to the detection result latching circuit 2560 via a detection result latching terminal 2561. The switch circuit 2580 controls the state between conducting or cut off between the installation detection terminals 2521 and 2522 according to the detection result.

In some embodiments, the detection pulse generating module 2540 may be referred to as a first circuit 2540, the detection result latching circuit 2560 may be referred to as a second circuit 2560, the switch circuit 2580 may be referred to as a third circuit 2580, the detection determining circuit 2570 may be referred to as a fourth circuit 2570, the switch circuit coupling terminal 2581 may be referred to as a first terminal 2581 and the detection result terminal 2571 may be referred to as a second terminal 2571, the pulse signal output terminal 2541 may be referred to as a third terminal 2541, the detection result latching terminal 2561 may be referred to as a fourth terminal 2561, the installation detection terminal 2521 may be referred to as a first installation detection terminal 2521, and the installation detection terminal 2522 may be referred to as a second installation detection terminal 2522. In this exemplary embodiment, the fourth circuit 2570 is coupled to the third circuit 2580 and the second circuit 2560 via the first terminal 2581 and the second terminal 2571, respectively, the second circuit 2560 is also coupled to the first circuit 2540 and the third circuit 2580 via the third terminal 2541 and the fourth terminal 2561, respectively.

In some embodiments, the fourth circuit 2570 is configured for detecting a signal between the first installation detection terminal 2521 and the second installation detection terminal 2522 through the first terminal 2581 and the third circuit 2580. For example, because of the above configuration, the fourth circuit 2570 is capable of detecting and determining whether a current passing through the first installation detection terminal 2521 and the second installation detection terminal 2522 is below or above a predetermined current value and transmitting or providing a detection result signal to the second circuit 2560 via the second terminal 2571.

In some embodiments, the first circuit 2540 generates a pulse signal through the second circuit 2560 to make the third circuit 2580 working in a conducting state during the

40

pulse signal. Meanwhile, as a result, the power loop of the LED tube lamp between the installation detection terminals 2521 and 2522 is thus conducting as well. The fourth circuit 2570 detects a sampling signal on the power loop and generates a signal based on a detection result to inform the second circuit 2560 of a time point for latching (storing) the detection result received by the second circuit 2560 from the fourth circuit 2570. For example, the fourth circuit 2570 may be a circuit configured to generate a signal that causes a latching circuit, such as the second circuit 2560 to enter and remain in a state that corresponds to one of a conducting state or a cut-off state for the LED tube lamp. The second circuit 2560 stores the detection result according to the detection result signal (or detection result signal and pulse signal), and transmits or provides the detection result to the third circuit 2580 coupled to the second circuit 2560 via the fourth terminal 2561. The third circuit 2580 receives the detection result transmitted from the second circuit 2560 and controls the state between conducting or cut off between the installation detection terminals 2521 and 2522 according to the detection result. It should be noted that the labels "first," "second," "third," etc., described in connection with these embodiments can be interchangeable and are merely used here in order to more easily differentiate the different circuits, nodes, and other components from each other.

Referring to FIG. 15C, a block diagram of a detection pulse generating module in accordance with certain embodiments is illustrated. A detection pulse generating module 2640 may be a circuit that includes multiple capacitors 2642, 2645, and 2646, multiple resistors 2643, 2647, and 2648, two buffers 2644 and 2651, an inverter 2650, a diode 2649, and an OR gate 2652. The capacitor 2642 may be referred to as a first capacitor 2642, the capacitor 2645 may be referred to as a second capacitor 2645, and the capacitor 2646 may be referred to as a third capacitor 2646. The resistor 2643 may be referred to as a first resistor 2643, the resistor 2647 may be referred to as a second resistor 2647, and the resistor 2648 may be referred to as a third resistor 2648. The buffer 2644 may be referred to as a first buffer 2644 and the buffer 2651 may be referred to as a second buffer 2651. The diode 2649 may be referred to as a first diode 2649 and the OR gate 2652 may be referred to as a first OR gate 2652. With use or operation, the capacitor 2642 and the resistor 2643 connect in series between a driving voltage (e.g., a driving voltage source, which may be a node of a power supply), such as VCC usually defined as a high logic level voltage, and a reference voltage (or potential), such as ground potential in this embodiment. The connection node between the capacitor 2642 and the resistor 2643 is coupled to an input terminal of the buffer 2644. In this exemplary embodiment, the buffer 2644 includes two inverters connected in series between an input terminal and an output terminal of the buffer 2644. The resistor 2647 is coupled between the driving voltage, e.g., VCC, and an input terminal of the inverter 2650. The resistor 2648 is coupled between an input terminal of the buffer 2651 and the reference voltage, e.g. ground potential in this embodiment. An anode of the diode 2649 is grounded and a cathode of the diode 2649 is coupled to the input terminal of the buffer 2651. First ends of the capacitors 2645 and 2646 are jointly coupled to an output terminal of the buffer 2644, and second, opposite ends of the capacitors 2645 and 2646 are respectively coupled to the input terminal of the inverter 2650 and the input terminal of the buffer 2651. In this exemplary embodiment, the buffer 2651 includes two inverters connected in series between an input terminal and an output terminal of the buffer 2651. An output terminal of the

US 9,841,174 B2

41

inverter **2650** and an output terminal of the buffer **2651** are coupled to two input terminals of the OR gate **2652**. According to certain embodiments, the voltage (or potential) for "high logic level" and "low logic level" mentioned in this specification are all relative to another voltage (or potential) or a certain reference voltage (or potential) in circuits, and further may be described as "logic high logic level" and "logic low logic level."

When an end cap of an LED tube lamp is inserted into a lamp socket and the other end cap thereof is electrically coupled to a human body, or when both end caps of the LED tube lamp are inserted into the lamp socket, the LED tube lamp is conductive with electricity. At this moment, the installation detection module (e.g., the installation detection module **2520** as illustrated in FIG. **15A**) enters a detection stage. The voltage on the connection node of the capacitor **2642** and the resistor **2643** is high initially (equals to the driving voltage, VCC) and decreases with time to zero finally. The input terminal of the buffer **2644** is coupled to the connection node of the capacitor **2642** and the resistor **2643**, so the buffer **2644** outputs a high logic level signal at the beginning and changes to output a low logic level signal when the voltage on the connection node of the capacitor **2642** and the resistor **2643** decreases to a low logic trigger logic level. As a result, the buffer **2644** is configured to produce an input pulse signal and then remain in a low logic level thereafter (stops outputting the input pulse signal.) The width for the input pulse signal may be described as equal to one (initial setting) time period, which is determined by the capacitance value of the capacitor **2642** and the resistance value of the resistor **2643**.

Next, the operations for the buffer **2644** to produce the pulse signal with the initial setting time period will be described below. Since the voltage on a first end of the capacitor **2645** and on a first end of the resistor **2647** is equal to the driving voltage VCC, the voltage on the connection node of both of them is also a high logic level. The first end of the resistor **2648** is grounded and the first end of the capacitor **2646** receives the input pulse signal from the buffer **2644**, so the connection node of the capacitor **2646** and the resistor **2648** has a high logic level voltage at the beginning but this voltage decreases with time to zero (in the meantime, the capacitor stores the voltage being equal to or approaching the driving voltage VCC.) Accordingly, initially the inverter **2650** outputs a low logic level signal and the buffer **2651** outputs a high logic level signal, and hence the OR gate **2652** outputs a high logic level signal (a first pulse signal) at the pulse signal output terminal **2541**. At this moment, the detection result latching circuit **2560** (as illustrated in FIG. **15B**) stores the detection result for the first time according to the detection result signal received from the detection determining circuit **2570** (as illustrated in FIG. **15B**) and the pulse signal generated at the pulse signal output terminal **2541**. During that initial pulse time period, as illustrated in FIG. **15B**, the detection pulse generating module **2540** outputs a high logic level signal, which results in the detection result latching circuit **2560** outputting the result of that high logic level signal.

When the voltage on the connection node of the capacitor **2646** and the resistor **2648** decreases to the low logic trigger logic level, the buffer **2651** changes to output a low logic level signal to make the OR gate **2652** output a low logic level signal at the pulse signal output terminal **2541** (stops outputting the first pulse signal.) The width of the first pulse signal output from the OR gate **2652** is determined by the capacitance value of the capacitor **2646** and the resistance value of the resistor **2648**.

42

The operation after the buffer **2644** stops outputting the pulse signal is described as below. For example, the operation may be initially in an operating stage. Since the capacitor **2646** stores the voltage being almost equal to the driving voltage VCC, and when the buffer **2644** instantaneously changes its output from a high logic level signal to a low logic level signal, the voltage on the connection node of the capacitor **2646** and the resistor **2648** is below zero but will be pulled up to zero by the diode **2649** rapidly charging the capacitor **2646**. Therefore, the buffer **2651** still outputs a low logic level signal.

In some embodiments, when the buffer **2644** instantaneously changes its output from a high logic level signal to a low logic level signal, the voltage on the one end of the capacitor **2645** also changes from the driving voltage VCC to zero instantly. This makes the connection node of the capacitor **2645** and the resistor **2647** have a low logic level signal. At this moment, the output of the inverter **2650** changes to a high logic level signal to make the OR gate output a high logic level signal (a second pulse signal) at the pulse signal output terminal **2541**. The detection result latching circuit **2560** as illustrated in FIG. **15B** stores the detection result for a second time according to the detection result signal received from the detection determining circuit **2570** (as illustrated in FIG. **15B**) and the pulse signal generated at the pulse signal output terminal **2541**. Next, the driving voltage VCC charges the capacitor **2645** through the resistor **2647** to make the voltage on the connection node of the capacitor **2645** and the resistor **2647** increase with time to the driving voltage VCC. When the voltage on the connection node of the capacitor **2645** and the resistor **2647** increases to reach a high logic trigger logic level, the inverter **2650** outputs a low logic level signal again to make the OR gate **2652** stop outputting the second pulse signal. The width of the second pulse signal is determined by the capacitance value of the capacitor **2645** and the resistance value of the resistor **2647**.

As those mentioned above, in certain embodiments, the detection pulse generating module **2640** generates two high logic level pulse signals in the detection stage, which are the first pulse signal and the second pulse signal. These pulse signals are output from the pulse signal output terminal **2541**. Moreover, there is an interval with a defined time between the first and second pulse signals (e.g., an opposite-logic signal, which may have a low logic level when the pulse signals have a high logic level), and the defined time is determined by the capacitance value of the capacitor **2642** and the resistance value of the resistor **2643**.

From the detection stage entering the operating stage, the detection pulse generating module **2640** does not produce the pulse signal any more, and keeps the pulse signal output terminal **2541** on a low logic level potential. As described herein, the operating stage is the stage following the detection stage (e.g., following the time after the second pulse signal ends). The operating stage occurs when the LED tube lamp is at least partly connected to a power source, such as provided in a lamp socket. For example, the operating stage may occur when part of the LED tube lamp, such as only one side of the LED tube lamp, is properly connected to one side of a lamp socket, and part of the LED tube lamp is either connected to a high impedance, such as a person, and/or is improperly connected to the other side of the lamp socket (e.g., is misaligned so that the metal contacts in the socket do not contact metal contacts in the LED tube lamp). The operating stage may also occur when the entire LED tube lamp is properly connected to the lamp socket.



## US 9,841,174 B2

43

Referring to FIG. 15D, a detection determining circuit in accordance with certain embodiments is illustrated. An exemplary detection determining circuit 2670 includes a comparator 2671 and a resistor 2672. The comparator 2671 may also be referred to as a first comparator 2671 and the resistor 2672 may also be referred to as a fifth resistor 2672. A negative input terminal of the comparator 2671 receives a reference logic level signal (or a reference voltage)  $V_{ref}$ , a positive input terminal thereof is grounded through the resistor 2672 and is also coupled to a switch circuit coupling terminal 2581. Referring to FIGS. 15B and 15D, the signal flowing into the switch circuit 2580 from the installation detection terminal 2521 outputs to the switch circuit coupling terminal 2581 to the resistor 2672. When the current of the signal passing through the resistor 2672 reaches a certain level (for example, bigger than or equal to a defined current for installation, (e.g. 2 A) and this makes the voltage on the resistor 2672 higher than the reference voltage  $V_{ref}$  (referring to two end caps inserted into the lamp socket,) the comparator 2671 produces a high logic level detection result signal and outputs it to the detection result terminal 2571. For example, when an LED tube lamp is correctly installed on a lamp socket, the comparator 2671 outputs a high logic level detection result signal at the detection result terminal 2571, whereas the comparator 2671 generates a low logic level detection result signal and outputs it to the detection result terminal 2571 when a current passing through the resistor 2672 is insufficient to make the voltage on the resistor 2672 higher than the reference voltage  $V_{ref}$  (referring to only one end cap inserted into the lamp socket.) Therefore, in some embodiments, when the LED tube lamp is incorrectly installed on the lamp socket or one end cap thereof is inserted into the lamp socket but the other one is grounded by an object such as a human body, the current will be too small to make the comparator 2671 output a high logic level detection result signal to the detection result terminal 2571.

Referring to FIG. 15E, a schematic detection result latching circuit according to some embodiments of the present invention is illustrated. A detection result latching circuit 2660 includes a D flip-flop 2661, a resistor 2662, and an OR gate 2663. The D flip-flop 2661 may also be referred to as a first D flip-flop 2661, the resistor 2662 may also be referred to as a fourth resistor 2662, and the OR gate 2663 may also be referred to as a second OR gate 2663. The D flip-flop 2661 has a CLK input terminal coupled to a detection result terminal 2571, and a D input terminal coupled to a driving voltage VCC. When the detection result terminal 2571 first outputs a low logic level detection result signal, the D flip-flop 2661 initially outputs a low logic level signal at a Q output terminal thereof, but the D flip-flop 2661 outputs a high logic level signal at the Q output terminal thereof when the detection result terminal 2571 outputs a high logic level detection result signal. The resistor 2662 is coupled between the Q output terminal of the D flip-flop 2661 and a reference voltage, such as ground potential. When the OR gate 2663 receives the first or second pulse signals from the pulse signal output terminal 2541 or receives a high logic level signal from the Q output terminal of the D flip-flop 2661, the OR gate 2663 outputs a high logic level detection result latching signal at a detection result latching terminal 2561. The detection pulse generating module 2640 only in the detection stage outputs the first and the second pulse signals to make the OR gate 2663 output the high logic level detection result latching signal, and thus the D flip-flop 2661 decides the detection result latching signal to be the high logic level or the low logic level the rest of the time, e.g.,

44

including the operating stage after the detection stage. Accordingly, when the detection result terminal 2571 has no high logic level detection result signal, the D flip-flop 2661 keeps a low logic level signal at the Q output terminal to make the detection result latching terminal 2561 also keep a low logic level detection result latching signal in the detection stage. On the contrary, once the detection result terminal 2571 has a high logic level detection result signal, the D flip-flop 2661 outputs and keeps a high logic level signal (e.g., based on VCC) at the Q output terminal. In this way, the detection result latching terminal 2561 keeps a high logic level detection result latching signal in the operating stage as well.

Referring to FIG. 15F, a schematic switch circuit according to some embodiments is illustrated. A switch circuit 2680 includes a transistor, such as a bipolar junction transistor (BJT) 2681, as being a power transistor, which has the ability of dealing with high current/power and is suitable for the switch circuit. The BJT 2681 may also be referred to as a first transistor 2681. The BJT 2681 has a collector coupled to an installation detection terminal 2521, a base coupled to a detection result latching terminal 2561, and an emitter coupled to a switch circuit coupling terminal 2581. When the detection pulse generating module 2640 produces the first and second pulse signals, the BJT 2681 is in a transient conduction state. This allows the detection determining circuit 2670 to perform the detection for determining the detection result latching signal to be a high logic level or a low logic level. When the detection result latching circuit 2660 outputs a high logic level detection result latching signal at the detection result latching terminal 2561, the BJT 2681 is in the conducting state to make the installation detection terminals 2521 and 2522 conducting. In contrast, when the detection result latching circuit 2660 outputs a low logic level detection result latching signal at the detection result latching terminal 2561 and the output from detection pulse generating module 2640 is a low logic level, the BJT 2681 is cut-off or in the blocking state to make the installation detection terminals 2521 and 2522 cut-off or blocking.

Since the external driving signal is an AC signal and in order to avoid the detection error resulting from the logic level of the external driving signal being just around zero when the detection determining circuit 2670 detects, the detection pulse generating module 2640 generates the first and second pulse signals to let the detection determining circuit 2670 perform two detections. So the issue of the logic level of the external driving signal being just around zero in a single detection can be avoided. In some cases, the time difference between the productions of the first and second pulse signals is not multiple times of half one cycle of the external driving signal. For example, it does not correspond to the multiple phase differences of 180 degrees of the external driving signal. In this way, when one of the first and second pulse signals is generated and unfortunately the external driving signal is around zero, it can be avoided that the external driving signal is again around zero when the other pulse signal is generated.

The time difference between the productions of the first and second pulse signals, for example, an interval with a defined time between both of them can be represented as following:

$$\text{the interval}=(X+Y)(T/2),$$

where T represents the cycle of an external driving signal, X is a natural number,  $0<Y<1$ , with Y in some embodiments in the range of 0.05-0.95, and in some embodiments in the range of 0.15-0.85.

US 9,841,174 B2

45

Furthermore, in order to avoid the installation detection module entering the detection stage from misjudgment resulting from the logic level of the driving voltage VCC being too small, the first pulse signal can be set to be produced when the driving voltage VCC reaches or is higher than a defined logic level. For example, in some embodiments, the detection determining circuit 2670 works after the driving voltage VCC reaching a high enough logic level in order to prevent the installation detection module from misjudgment due to an insufficient logic level.

According to the examples mentioned above, when one end cap of an LED tube lamp is inserted into a lamp socket and the other one floats or electrically couples to a human body or other grounded object, the detection determining circuit outputs a low logic level detection result signal because of high impedance. The detection result latching circuit stores the low logic level detection result signal based on the pulse signal of the detection pulse generating module, making it as the low logic level detection result latching signal, and keeps the detection result in the operating stage, without changing the logic value. In this way, the switch circuit keeps cutting-off or blocking instead of conducting continually. And further, the electric shock situation can be prevented and the requirement of safety standard can also be met. On the other hand, when two end caps of the LED tube lamp are correctly inserted into the lamp socket, the detection determining circuit outputs a high logic level detection result signal because the impedance of the circuit for the LED tube lamp itself is small. The detection result latching circuit stores the high logic level detection result signal based on the pulse signal of the detection pulse generating module, making it as the high logic level detection result latching signal, and keeps the detection result in the operating stage. So the switch circuit keeps conducting to make the LED tube lamp work normally in the operating stage.

In some embodiments, when one end cap of the LED tube lamp is inserted into the lamp socket and the other one floats or electrically couples to a human body, the detection determining circuit outputs a low logic level detection result signal to the detection result latching circuit, and then the detection pulse generating module outputs a low logic level signal to the detection result latching circuit to make the detection result latching circuit output a low logic level detection result latching signal to make the switch circuit cutting-off or blocking. As such, the switch circuit blocking makes the installation detection terminals, e.g. the first and second installation detection terminals, blocking. As a result, the LED tube lamp is in non-conducting or blocking state.

However, in some embodiments, when two end caps of the LED tube lamp are correctly inserted into the lamp socket, the detection determining circuit outputs a high logic level detection result signal to the detection result latching circuit to make the detection result latching circuit output a high logic level detection result latching signal to make the switch circuit conducting. As such, the switch circuit conducting makes the installation detection terminals, e.g. the first and second installation detection terminals, conducting. As a result, the LED tube lamp operates in a conducting state.

Thus, according to the operation of the installation detection module, a first circuit, upon connection of at least one end of the LED tube lamp to a lamp socket, generates and outputs two pulses, each having a pulse width, with a time period between the pulses. The first circuit may include various of the elements described above configured to output the pulses to a base of a transistor (e.g., a BJT transistor) that serves as a switch. The pulses occur during a detection stage

46

for detecting whether the LED tube lamp is properly connected to a lamp socket. The timing of the pulses may be controlled based on the timing of various parts of the first circuit changing from high to low logic levels, or vice versa.

The pulses can be timed such that, during that detection stage time, if the LED tube lamp is properly connected to the lamp socket (e.g., both ends of the LED tube lamp are correctly connected to conductive terminals of the lamp socket), at least one of the pulse signals occurs when an AC current from a driving signal is at a non-zero level. For example, the pulse signals can occur at intervals that are different from half of the period of the AC signal. For example, respective start points or mid points of the pulse signals, or a time between an end of the first pulse signal and a beginning of the second pulse signal may be separated by an amount of time that is different from half of the period of the AC signal (e.g., it may be between 0.05 and 0.95 percent of a multiple of half of the period of the AC signal). During a pulse that occurs when the AC signal is at a non-zero level, a switch that receives the AC signal at the non-zero level may be turned on, causing a latch circuit to change states such that the switch remains permanently on so long as the LED tube lamp remains properly connected to the lamp socket. For example, the switch may be configured to turn on when each pulse is output from the first circuit. The latch circuit may be configured to change state only when the switch is on and the current output from the switch is above a threshold value, which may indicate a proper connection to a light socket. As a result, the LED tube lamp operates in a conducting state.

On the other hand, if both pulses occur when a driving signal at the LED tube lamp has a near-zero current level, or a current level below a particular threshold, then the state of the latch circuit is not changed, and so the switch is only on during the two pulses, but then remains permanently off after the pulses and after the detection mode is over. For example, the latch circuit can be configured to remain in its present state if the current output from the switch is below the threshold value. In this manner, the LED tube lamp remains in a non-conducting state, which prevents electric shock, even though part of the LED tube lamp is connected to an electrical power source.

It is worth noting that according to certain embodiments, the width of the pulse signal generated by the detection pulse generating module is between 10  $\mu$ s to 1 ms, and it is used to make the switch circuit conducting for a short period when the LED tube lamp conducts instantaneously. In some embodiments, a pulse current is generated to pass through the detection determining circuit for detecting and determining. Since the pulse is for a short time and not for a long time, the electric shock situation will not occur. Furthermore, the detection result latching circuit also keeps the detection result during the operating stage (e.g., the operating stage being the period after the detection stage and during which part of the LED tube lamp is still connected to a power source), and no longer changes the detection result stored previously complying with the circuit state changing. A situation resulting from changing the detection result can thus be avoided. In some embodiments, the installation detection module, such as the switch circuit, the detection pulse generating module, the detection result latching circuit, and the detection determining circuit, could be integrated into a chip and then embedded in circuits for saving the circuit cost and layout space.

As discussed in the above examples, in some embodiments, an LED tube lamp includes an installation detection circuit comprising a first circuit configured to output two

US 9,841,174 B2

47

pulse signals, the first pulse signal output at a first time and the second pulse signal output at a second time after the first time, and a switch configured to receive an LED driving signal and to receive the two pulse signals, wherein the two pulse signals control turning on and off of the switch. The installation detection circuit may be configured to, during a detection stage, detect during each of the two pulse signals whether the LED tube lamp is properly connected to a lamp socket. When it is not detected during either pulse signal that the LED tube lamp is properly connected to the lamp socket, the switch may remain in an off state after the detection stage. When it is detected during at least one of the pulse signals that the LED tube lamp is properly connected to the lamp socket, the switch may remain in an on state after the detection stage. The two pulse signals may occur such that they are separated by a time different from a multiple of half of a period of the LED driving signal, and such that at least one of them does not occur when the LED driving signal has a current value of substantially zero. It should be noted that although a circuit for producing two pulse signals is described, the disclosure is not intended to be limiting as such. For example, a circuit may be implemented such that a plurality of pulse signals may occur, wherein at least two of the plurality of pulse signals are separated by a time different from a multiple of half of a period of the LED driving signal, and such that at least one of the plurality of pulse signals does not occur when the LED driving signal has a current value of substantially zero.

Referring to FIG. 15G, an installation detection module according to an exemplary embodiment is illustrated. The installation detection module includes a detection pulse generating module 2740 (which may also be referred to as a detection pulse generating circuit or a first circuit), a detection result latching circuit 2760 (which may also be referred to as a second circuit), a switch circuit 2780 (which may also be referred to as a third circuit), and a detection determining circuit 2770 (which may also be referred to as a fourth circuit). The detection pulse generating module 2740 is coupled (e.g., electrically connected) to the detection result latching circuit 2760 via a path 2741, and is configured to generate at least one pulse signal. A path as described herein may include a conductive line connecting between two components, circuits, or modules, and may include opposite ends of the conductive line connected to the respective components, circuits or modules. The detection result latching circuit 2760 is coupled (e.g., electrically connected) to the switch circuit 2780 via a path 2761, and is configured to receive and output the pulse signal(s) from the detection pulse generating module 2740. The switch circuit 2780 is coupled (e.g., electrically connected) to one end (e.g., a first installation detection terminal 2521) of a power loop of an LED tube lamp and the detection determining circuit 2770, and is configured to receive the pulse signal(s) output from the detection result latching circuit 2760, and configured to conduct (or turn on) during the pulse signal(s) so as to cause the power loop of the LED tube lamp to be conductive. The detection determining circuit 2770 is coupled (e.g., electrically connected) to the switch circuit 2780, the other end (e.g., a second installation detection terminal 2522) of the power loop of the LED tube lamp and the detection result latching circuit 2760, and is configured to detect at least one sampling signal on the power loop when the switch circuit 2780 and the power loop are conductive, so as to determine an installation state between the LED tube lamp and a lamp socket. The detection determining circuit 2770 is further configured to transmit detection result(s) to the detection result latching circuit

48

2760 for next control. In some embodiments, the detection pulse generating module 2740 is further coupled (e.g., electrically connected) to the output of the detection result latching circuit 2760 to control the time of the pulse signal(s).

In some embodiments, one end of a first path 2781 is coupled to a first node of the detection determining circuit 2770 and the opposite end of the first path 2781 is coupled to a first node of the switch circuit 2780. In some embodiments, a second node of the detection determining circuit 2770 is coupled to the second installation detection terminal 2522 of the power loop and a second node of the switch circuit 2780 is coupled to the first installation detection terminal 2521 of the power loop. In some embodiments, one end of a second path 2771 is coupled to a third node of the detection determining circuit 2770 and the opposite end of the second path 2771 is coupled to a first node of the detection result latching circuit 2760, one end of a third path 2741 is coupled to a second node of the detection result latching circuit 2760 and the opposite end of the third path 2741 is coupled to a first node of the detection pulse generating circuit 2740. In some embodiments, one end of a fourth path 2761 is coupled to a third node of the switch circuit 2780 and the opposite end of the fourth path 2761 is coupled to a third node of the detection result latching circuit 2760. In some embodiments, the fourth path 2761 is also coupled to a second node of the detection pulse generating circuit 2740.

In some embodiments, the detection determining circuit 2770 is configured for detecting a signal between the first installation detection terminal 2521 and the second installation detection terminal 2522 through the first path 2781 and the switch circuit 2780. For example, because of the above configuration, the detection determining circuit 2770 is capable of detecting and determining whether a current passing through the first installation detection terminal 2521 and the second installation detection terminal 2522 is below or above a predetermined current value and transmitting or providing a detection result signal to the detection result latching circuit 2760 via the second path 2771.

In some embodiments, the detection pulse generating circuit 2740 generates a pulse signal through the detection result latching circuit 2760 to make the switch circuit 2780 working in a conducting state during the pulse signal. Meanwhile, as a result, the power loop of the LED tube lamp between the installation detection terminals 2521 and 2522 is thus conducting as well. The detection determining circuit 2770 detects a sampling signal on the power loop and generates a signal based on a detection result to inform the detection result latching circuit 2760 of a time point for latching (storing) the detection result received by the detection result latching circuit 2760 from the detection determining circuit 2770. For example, the detection determining circuit 2770 may be a circuit configured to generate a signal that causes a latching circuit, such as the detection result latching circuit 2760 to enter and remain in a state that corresponds to one of a conducting state or a cut-off state for the LED tube lamp. The detection result latching circuit 2760 stores the detection result according to the detection result signal (or detection result signal and pulse signal), and transmits or provides the detection result to the switch circuit 2780 coupled to the third node of the detection result latching circuit 2760 via the fourth path 2761. The switch circuit 2780 receives the detection result transmitted from the detection result latching circuit 2760 via the third node of the switch circuit 2780 and controls the state between

## US 9,841,174 B2

49

conducting or cut off between the installation detection terminals 2521 and 2522 according to the detection result.

The detail circuit architecture and the entire operation thereof of each of the detection pulse generating module 2740 (or circuit), the detection result latching circuit 2760, the switch circuit 2780, and the detection determining circuit 2770 will be described below.

Referring to FIG. 15H, a detection pulse generating module according to an exemplary embodiment is illustrated. The detection pulse generating module 2740 includes: a resistor 2742 (which also may be referred to as a sixth resistor), a capacitor 2743 (which also may be referred to as a fourth capacitor), a Schmitt trigger 2744, a resistor 2745 (which also may be referred to as a seventh resistor), a transistor 2746 (which also may be referred to as a second transistor), and a resistor 2747 (which also may be referred to as an eighth resistor).

In some embodiments, one end of the resistor 2742 is connected to a driving signal, for example, Vcc, and the other end of the resistor 2742 is connected to one end of the capacitor 2743. The other end of the capacitor 2743 is connected to a ground node. In some embodiments, the Schmitt trigger 2744 has an input end and an output end, the input end connected to a connection node of the resistor 2742 and the capacitor 2743, the output end connected to the detection result latching circuit 2760 via the third path 2741 (FIG. 15G). In some embodiments, one end of the resistor 2745 is connected to the connection node of the resistor 2742 and the capacitor 2743 and the other end of the resistor 2745 is connected to a collector of the transistor 2746. An emitter of the transistor 2746 is connected to a ground node. In some embodiments, one end of the resistor 2747 is connected to a base of the transistor 2746 and the other end of the resistor 2747 is connected to the detection result latching circuit 2760 (FIG. 15G) and the switch circuit 2780 (FIG. 15G) via the fourth path 2761. In certain embodiments, the detection pulse generating module 2740 further includes: a Zener diode 2748, having an anode and a cathode, the anode connected to the other end of the capacitor 2743 to the ground, the cathode connected to the end of the capacitor 2743 (the connection node of the resistor 2742 and the capacitor 2743).

Referring to FIG. 15I, a detection result latching circuit according to an exemplary embodiment is illustrated. The detection result latching circuit 2760 includes: a D flip-flop 2762 (which also may be referred to as a second D flip-flop), having a data input end D, a clock input end CLK, and an output end Q, the data input end D connected to the driving signal mentioned above (e.g., Vcc), the clock input end CLK connected to the detection determining circuit 2770 (FIG. 15G); and an OR gate 2763 (which also may be referred to as a third OR gate), having a first input end, a second input end, and an output end, the first input end connected to the output end of the Schmitt trigger 2744 (FIG. 15H), the second input end connected to the output end Q of the D flip-flop 2762, the output end of the OR gate 2763 connected to the other end of the resistor 2747 (FIG. 15H) and the switch circuit 2780 (FIG. 15G).

Referring to FIG. 15J, a switch circuit according to an exemplary embodiment is illustrated. The switch circuit 2780 includes: a transistor 2782 (which also may be referred to as a third transistor), having a base, a collector, and an emitter, the base connected to the output of the OR gate 2763 via the fourth path 2761 (FIG. 15I), the collector connected to one end of the power loop, such as the first installation detection terminal 2521, the emitter connected to the detection determining circuit 2770 (FIG. 15G). In some embodi-

50

ments, the transistor 2782 may be replaced by other equivalently electronic parts, e.g., a MOSFET.

Referring to FIG. 15K, a detection determining circuit according to an exemplary embodiment is illustrated. The detection determining circuit 2770 includes: a resistor 2774 (which also may be referred to as a ninth resistor), one end of the resistor 2774 connected to the emitter of the transistor 2782 (FIG. 15J), the other end of the resistor 2774 connected to the other end of the power loop, such as the second installation detection terminal 2522; a diode 2775 (which also may be referred to as a second diode), having an anode and a cathode, the anode connected to an end of the resistor 2744 that is not connected to a ground node; a comparator 2772 (which also may be referred to as a second comparator), having a first input end, a second input end, and an output end; a comparator 2773 (which also may be referred to as a third comparator), having a first input end, a second input end, and an output end; a resistor 2776 (which also may be referred to as a tenth resistor); a resistor 2777 (which also may be referred to as an eleventh resistor); and a capacitor 2778 (which also may be referred to as a fifth capacitor).

In some embodiments, the first input end of the comparator 2772 is connected to a predefined signal, for example, a reference voltage, Vref=1.3V, but the reference voltage value is not limited thereto, the second input end of the comparator 2772 is connected to the cathode of the diode 2775, and the output end of the comparator 2772 is connected to the clock input end of the D flip-flop 2762 (FIG. 15I). In some embodiments, the first input end of the comparator 2773 is connected to the cathode of the diode 2775, the second input end of the comparator 2773 is connected to another predefined signal, for example, a reference voltage, Vref=0.3V, but the reference voltage value is not limited thereto, and the output end of the comparator 2773 is connected to the clock input end of the D flip-flop 2762 (FIG. 15I). In some embodiments, one end of the resistor 2776 is connected to the driving signal mentioned above (e.g., Vcc) and the other end of the resistor 2776 is connected to the second input end of the comparator 2772 and one end of the resistor 2777 that is not connected to a ground node and the other end of the resistor 2777 is connected to the ground node. In some embodiments, the capacitor 2778 is connected to the resistor 2777 in parallel. In certain embodiments, the diode 2775, the comparator 2773, the resistors 2776 and 2777, and the capacitor 2778 may be omitted, and the second input end of the comparator 2772 may be directly connected to the end of the resistor 2774 (e.g., the end of the resistor 2774 that is not connected to the ground node) when the diode 2775 is omitted. In certain embodiments, the resistor 2774 may include two resistors connected in parallel based on the consideration of power consumption having an equivalent resistance value ranging from about 0.1 ohm to about 5 ohm.

In some embodiments, some parts of the installation detection module may be integrated into an integrated circuit (IC) in order to provide reduced circuit layout space resulting in reduced manufacturing cost of the circuit. For example, the Schmitt trigger 2744 of the detection pulse generating module 2740, the detection result latching circuit 2760, and the two comparators 2772 and 2773 of the detection determining circuit 2770 may be integrated into an IC, but the disclosure is not limited thereto.

An operation of the installation detection module will be described in more detail in accordance with some example embodiments. In one exemplary embodiment, the capacitor voltage may not mutate; the voltage of the capacitor in the

## US 9,841,174 B2

## 51

power loop of the LED tube lamp before the power loop being conductive is zero and the capacitor's transient response may appear to have a short-circuit condition; when the LED tube lamp is correctly installed to the lamp socket, the power loop of the LED tube lamp in transient response may have a smaller current-limiting resistance and a bigger peak current; and when the LED tube lamp is incorrectly installed to the lamp socket, the power loop of the LED tube lamp in transient response may have a bigger current-limiting resistance and a smaller peak current. This embodiment may also meet the UL standard to make the leakage current of the LED tube lamp less than 5 MIU. The following table illustrates the current comparison in a case when the LED tube lamp works normally (e.g., when the two end caps of the LED tube lamp are correctly installed to the lamp socket) and in a case when the LED tube lamp is incorrectly installed to the lamp socket (e.g., when one end cap of the LED tube lamp is installed to the lamp socket but the other one is touched by a human body).

	Correct installation	Incorrect installation
Maximum transient current		$i_{pk\_max} = \frac{V_{in\_pk}}{R_{fuse} + 500} =$ $\frac{305 \times 1.414}{10 + 500} = 845 \text{ mA}$
Minimum transient current	$i_{pk\_min} = \frac{\Delta V_{in}}{R_{fuse}} = \frac{50}{10} = 5 \text{ A}$	

As illustrated in the above table, in the part of the denominator:  $R_{fuse}$  represents the resistance of the fuse of the LED tube lamp. For example, 10 ohm may be used, but the disclosure is not limited thereto, as resistance value for  $R_{fuse}$  in calculating the minimum transient current  $i_{pk\_min}$  and 510 ohm may be used as resistance value for  $R_{fuse}$  in calculating the maximum transient current  $i_{pk\_max}$  (an additional 500 ohms is used to emulate the conductive resistance of human body in transient response). In the part of the numerator: maximum voltage from the root-mean-square voltage ( $V_{max} = V_{rms} \times 1.414 = 305 \times 1.414$ ) is used in calculating the maximum transient current  $i_{pk\_max}$  and minimum voltage difference, for example, 50V (but the disclosure is not limited thereto) is used in calculating the minimum transient current  $i_{pk\_min}$ . Accordingly, when the LED tube lamp is correctly installed to the lamp socket (e.g., when two end caps of the LED tube lamp are installed to the lamp socket correctly) and works normally, its minimum transient current is 5 A. But, when the LED tube lamp is incorrectly installed to the lamp socket (e.g., when one end cap is installed to the lamp socket but the other one is touched by human body), its maximum transient current is only 845 mA. Therefore, certain examples of the disclosed embodiments use the current which passes transient response and flows through the capacitor in the LED power loop, such as the capacitor of the filtering circuit, to detect and determine the installation state between the LED tube lamp and the lamp socket. For example, such embodiments may detect whether the LED tube lamp is correctly installed to the lamp socket. Certain examples of the disclosed embodiments further provide a protection mechanism to protect the user from electric shock caused by touching the conductive part of the LED tube lamp which is incorrectly installed to the lamp socket. The embodiments mentioned above are used to

## 52

illustrate certain aspects of the disclosed invention but the disclosure is not limited thereto.

Further, referring to FIG. 15G again, in some embodiments, when an LED tube lamp is being installed to a lamp socket, after a period (e.g., the period utilized to determine the cycle of a pulse signal), the detection pulse generating module 2740 outputs a first high level voltage rising from a first low level voltage to the detection result latching circuit 2760 through a path 2741 (also referred to as a third path). The detection result latching circuit 2760 receives the first high level voltage, and then simultaneously outputs a second high level voltage to the switch circuit 2780 and the detection pulse generating module 2740 through a path 2761 (also referred to as a fourth path). In some embodiments, when the switch circuit 2780 receives the second high level voltage, the switch circuit 2780 conducts to cause the power loop of the LED tube lamp to be conductive as well. In this exemplary embodiment, the power loop at least includes the first installation detection terminal 2521, the switch circuit 2780, the path 2781 (also referred to as a first path), the detection determining circuit 2770, and the second installation detection terminal 2522. In the meantime, the detection pulse generating module 2740 receives the second high level voltage from the detection result latching circuit 2760, and after a period (e.g., the period utilized to determine the width (or period) of pulse signal), its output from the first high level voltage falls back to the first low level voltage (the first time of the first low level voltage, the first high level voltage, and the second time of the first low level voltage form a first pulse signal). In some embodiments, when the power loop of the LED tube lamp is conductive, the detection determining circuit 2770 detects a first sampling signal, such as a voltage signal, on the power loop. When the first sampling signal is greater than or equal to a predefined signal, such as a reference voltage, the installation detection module determines that the LED tube lamp is correctly installed to the lamp socket according to the application principle of this disclosed embodiments described above. Therefore, the detection determining circuit 2770 included in the installation detection module outputs a third high level voltage (also referred to as a first high level signal) to the detection result latching circuit 2760 through a path 2771 (also referred to as a second path). The detection result latching circuit 2760 receives the third high level voltage (also referred to as the first high level signal) and continues to output a second high level voltage (also referred to as a second high level signal) to the switch circuit 2780. The switch circuit 2780 receives the second high level voltage (also referred to as the second high level signal) and maintains conductive state to cause the power loop to remain conductive. The detection pulse generating module 2740 does not generate any pulse signal while the power loop remains conductive.

However, in some embodiments, when the first sampling signal is smaller than the predefined signal, the installation detection module, according to certain exemplary embodiments as described above, determines that the LED tube lamp has not been correctly installed to the lamp socket. Therefore, the detection determining circuit 2770 outputs a third low level voltage (also referred to as a first low level signal) to the detection result latching circuit 2760. The detection result latching circuit 2760 receives the third low level voltage (also referred to as the first low level signal) and continues to output a second low level voltage (also referred to as a second low level signal) to the switch circuit 2780. The switch circuit 2780 receives the second low level voltage (also referred to as the second low level signal) and then keeps blocking to cause the power loop to remain open.

US 9,841,174 B2

53

Accordingly, the occurrence of electric shock caused by touching the conductive part of the LED tube lamp which is incorrectly installed on the lamp socket can be sufficiently avoided.

In some embodiments, when the power loop of the LED tube lamp remains open for a period (a period that represents the cycle of pulse signal), the detection pulse generating module 2740 outputs the first high level voltage rising from the first low level voltage to the detection result latching circuit 2760 through the path 2741 once more. The detection result latching circuit 2760 receives the first high level voltage, and then simultaneously outputs a second high level voltage to the switch circuit 2780 and the detection pulse generating module 2740. In some embodiments, when the switch circuit 2780 receives the second high level voltage, the switch circuit 2780 conducts again to cause the power loop of the LED tube lamp (in this exemplary embodiment, the power loop at least includes the first installation detection terminal 2521, the switch circuit 2780, the path 2781, the detection determining circuit 2770, and the second installation detection terminal 2522) to be conductive as well. In the meantime, the detection pulse generating module 2740 receives the second high level voltage from the detection result latching circuit 2760, and after a period (a period that is utilized to determine the width (or period) of pulse signal), its output from the first high level voltage falls back to the first low level voltage (the third time of the first low level voltage, the second time of the first high level voltage, and the fourth time of the first low level voltage form a second pulse signal). In some embodiments, when the power loop of the LED tube lamp is conductive again, the detection determining circuit 2770 also detects a second sampling signal, such as a voltage signal, on the power loop yet again. When the second sampling signal is greater than or equal to the predefined signal, the installation detection module determines, according to certain exemplary embodiments described above, that the LED tube lamp is correctly installed to the lamp socket. Therefore, the detection determining circuit 2770 outputs a third high level voltage (also referred to as a first high level signal) to the detection result latching circuit 2760 through the path 2771. The detection result latching circuit 2760 receives the third high level voltage (also referred to as the first high level signal) and continues to output a second high level voltage (also referred to as a second high level signal) to the switch circuit 2780. The switch circuit 2780 receives the second high level voltage (also referred to as the second high level signal) and maintains a conductive state to cause the power loop to remain conductive. The detection pulse generating module 2740 does not generate any pulse signal while the power loop remains conductive.

In some embodiments, when the second sampling signal is smaller than the predefined signal, the installation detection module determines, according to certain exemplary embodiments described above, that the LED tube lamp has not been correctly installed to the lamp socket. Therefore, the detection determining circuit 2770 outputs the third low level voltage (also referred to as the first low level signal) to the detection result latching circuit 2760. The detection result latching circuit 2760 receives the third low level voltage (also referred to as the first low level signal) and continues to output the second low level voltage (also referred to as the second low level signal) to the switch circuit 2780. The switch circuit 2780 receives the second low level voltage (also referred to as the second low level signal) and then keeps blocking to cause the power loop to remain open.

54

Next, referring to FIG. 15H-FIG. 15K at the same time, in some embodiments when an LED tube lamp is being installed to a lamp socket, the capacitor 2743 is charged by the driving signal, for example, Vcc, through the resistor 2742. And when the voltage of the capacitor 2743 rises enough to trigger the Schmitt trigger 2744, the Schmitt trigger 2744 outputs a first high level voltage rising from a first low level voltage in an initial state to an input end of the OR gate 2763. After the OR gate 2763 receives the first high level voltage from the Schmitt trigger 2744, the OR gate 2763 outputs a second high level voltage to the base of the transistor 2782 and the resistor 2747. When the base of the transistor 2782 receives the second high level voltage from the OR gate 2763, the collector and the emitter of the transistor 2782 are conductive to further cause the power loop of the LED tube lamp (in this exemplary embodiment, the power loop at least includes the first installation detection terminal 2521, the transistor 2782, the resistor 2744, and the second installation detection terminal 2522) to be conductive as well. In the meantime, the base of the transistor 2746 receives the second high level voltage from the OR gate 2763 through the resistor 2747, and then the collector and the emitter of the transistor 2746 are conductive and grounded to cause the voltage of the capacitor 2743 to be discharged to the ground through the resistor 2745. In some embodiments, when the voltage of the capacitor 2743 is not enough to trigger the Schmitt trigger 2744, the Schmitt trigger 2744 outputs the first low level voltage falling from the first high level voltage (a first instance of a first low level voltage at a first time, followed by a first high level voltage, followed by a second instance of the first low level voltage at a second time form a first pulse signal). When the power loop of the LED tube lamp is conductive, the current passing through the capacitor in the power loop, such as, the capacitor of the filtering circuit, by transient response flows through the transistor 2782 and the resistor 2774 and forms a voltage signal on the resistor 2774. The voltage signal is compared to a reference voltage, for example, 1.3V, but the reference voltage is not limited thereto, by the comparator 2772. When the voltage signal is greater than and/or equal to the reference voltage, the comparator 2772 outputs a third high level voltage to the clock input end CLK of the D flip-flop 2762. In the meantime, since the data input end D of the D flip-flop 2762 is connected to the driving signal, the D flip-flop 2762 outputs a high level voltage (at its output end Q) to another input end of the OR gate 2763. This causes the OR gate 2763 to keep outputting the second high level voltage to the base of the transistor 2782, and further results in the transistor 2782 and the power loop of the LED tube lamp remaining in a conducting state. Besides, since the OR gate 2763 keeps outputting the second high level voltage to cause the transistor 2746 to be conductive to the ground, the capacitor 2743 is unable to reach an enough voltage to trigger the Schmitt trigger 2744.

However, when the voltage signal on the resistor 2774 is smaller than the reference voltage, the comparator 2772 outputs a third low level voltage to the clock input end CLK of the D flip-flop 2762. In the meantime, since the initial output of the D flip-flop 2762 is a low level voltage (e.g., zero voltage), the D flip-flop 2762 outputs a low level voltage (at its output end Q) to the other input end of the OR gate 2763. Moreover, the Schmitt trigger 2744 connected by the input end of the OR gate 2763 also restores outputting the first low level voltage, the OR gate 2763 thus keeps outputting the second low level voltage to the base of the transistor 2782, and further results in the transistor 2782 to remain in a blocking state (or an off state) and the power

## US 9,841,174 B2

55

loop of the LED tube lamp to remain in an open state. Still, since the OR gate 2763 keeps outputting the second low level voltage to cause the transistor 2764 to remain in a blocking state (or an off state), the capacitor 2743 is charged by the driving signal through the resistor 2742 once again for next (pulse signal) detection.

In some embodiments, the cycle (or interval) of the pulse signal is determined by the values of the resistor 2742 and the capacitor 2743. In certain cases, the cycle of the pulse signal may include a value ranging from about 3 milliseconds to about 500 milliseconds or may be ranging from about 20 milliseconds to about 50 milliseconds. In some embodiments, the width (or period) of the pulse signal is determined by the values of the resistor 2745 and the capacitor 2743. In certain cases, the width of the pulse signal may include a value ranging from about 1 microsecond to about 100 microseconds or may be ranging from about 10 microseconds to about 20 microseconds. The Zener diode 2748 provides a protection function but it may be omitted in certain cases. The resistor 2744 may include two resistors connected in parallel based on the consideration of power consumption in certain cases, and its equivalent resistance may include a value ranging from about 0.1 ohm to about 5 ohm. The resistors 2776 and 2777 provides the function of voltage division to make the input of the comparator 2773 bigger than the reference voltage, such as 0.3V, but the value of the reference voltage is not limited thereto. The capacitor 2778 provides the functions of regulation and filtering. The diode 2775 limits the signal to be transmitted in one way. In addition, the installation detection module disclosed by the example embodiments may also be adapted to other types of LED lighting equipment with dual-end power supply, e.g., the LED lamp directly using commercial power as its external driving signal, the LED lamp using the signal outputted from the ballast as its external driving signal, etc. However, the invention is not limited to the above example embodiments.

According to some embodiments, the present invention further provides a detection method adopted by a light-emitting device (LED) tube lamp for preventing a user from electric shock when the LED tube lamp is being installed on a lamp socket. The detection method includes: generating a first pulse signal by a detection pulse generating module, wherein the detection pulse generating module is configured in the LED tube lamp; receiving the first pulse signal through a detection result latching circuit by a switch circuit, and making the switch circuit conducting during the first pulse signal to cause a power loop of the LED tube lamp to be conductive, wherein the switch circuit is on the power loop; and detecting a first sampling signal on the power loop by a detection determining circuit as the power loop being conductive, and comparing the first sampling signal with a predefined signal, wherein when the first sampling signal is greater than or equal to the predefined signal, the detection method further includes: outputting a first high level signal by the detection determining circuit; receiving the first high level signal by the detection result latching circuit and outputting a second high level signal; and receiving the second high level signal by the switch circuit and conducting to cause the power loop to remain conductive.

In some embodiments, when the first sampling signal is smaller than the predefined signal, the detection method further includes: outputting a first low level signal by the detection determining circuit; receiving the first low level signal by the detection result latching circuit and outputting a second low level signal; and receiving the second low level

56

signal by the switch circuit and maintaining an off state of the switch circuit to cause the power loop to remain open.

In some embodiments, when the power loop remains open, the detection method further includes: generating a second pulse signal by the detection pulse generating module; receiving the second pulse signal through the detection result latching circuit by the switch circuit, and changing an off state of the switch circuit to a conductive state again during the second pulse signal to cause the power loop to be conductive once more; and detecting a second sampling signal on the power loop by the detection determining circuit as the power loop being conductive once more, and comparing the second sampling signal with the predefined signal, wherein when the second sampling signal is greater than or equal to the predefined signal, the detection method further includes: outputting the first high level signal by the detection determining circuit; receiving the first high level signal by the detection result latching circuit and outputting the second high level signal; and receiving the second high level signal by the switch circuit and maintaining a conductive state of the switch circuit to cause the power loop to remain conductive.

In some embodiments, when the second sampling signal is smaller than the predefined signal, the detection method further includes: outputting the first low level signal by the detection determining circuit; receiving the first low level signal by the detection result latching circuit and outputting the second low level signal; and receiving the second low level signal by the switch circuit and maintaining an off state of the switch circuit to cause the power loop to remain open.

In some embodiments, a period (or a width) of the first pulse signal is between 10 microseconds-1 millisecond, a period (or a width) of the second pulse signal is between 10 microseconds-1 millisecond.

In some embodiments, a time interval between the first and the second pulse signals (or a cycle of the pulse signal) includes  $(X+Y)(T/2)$ , where T is the cycle of the driving signal, X is an integer which is bigger than or equal to zero,  $0 < Y < 1$ .

In some embodiments, a period (or a width) of the first pulse signal is between 1 microsecond-100 microseconds, a period (or a width) of the second pulse signal is between 1 microsecond-100 microseconds.

In some embodiments, a time interval between the first and the second pulse signals (or a cycle of the pulse signal) is between 3 milliseconds-500 milliseconds.

In some embodiments, at least two protection elements, such as two fuses, are respectively connected between the internal circuits of the LED tube lamp and the conductive pins of the LED tube lamp, and which are on the power loop of the LED tube lamp. In some embodiments, four fuses are used for an LED tube lamp having power-supplied at its both end caps respectively having two conductive pins. In this case, for example, two fuses are respectively connected between two conductive pins of one end cap and between one of the two conductive pins of this end cap and the internal circuits of the LED tube lamp; and the other two fuses are respectively connected between two conductive pins of the other end cap and between one of the two conductive pins of the other end cap and the internal circuits of the LED tube lamp. In some embodiment, the capacitance between a power supply (or an external driving source) and the rectifying circuit of the LED tube lamp may be ranging from 0 to about 100 pF. In some embodiments, the above-mentioned installation detection module may be configured to use an external power supply.

US 9,841,174 B2

57

According to the design of the power supply module, the external driving signal may be a low frequency AC signal (e.g., commercial power), a high frequency AC signal (e.g., that provided by an electronic ballast), or a DC signal (e.g., that provided by a battery or external configured driving source), input into the LED tube lamp through a drive architecture of dual-end power supply. For the drive architecture of dual-end power supply, the external driving signal may be input by using only one end thereof as single-end power supply.

The LED tube lamp may omit the rectifying circuit in the power supply module when the external driving signal is a DC signal.

According to the design of the rectifying circuit in the power supply module, there may be a dual rectifying circuit. First and second rectifying circuits of the dual rectifying circuit are respectively coupled to the two end caps disposed on two ends of the LED tube lamp. The dual rectifying circuit is applicable to the drive architecture of dual-end power supply. Furthermore, the LED tube lamp having at least one rectifying circuit is applicable to the drive architecture of a low frequency AC signal, high frequency AC signal or DC signal.

The dual rectifying circuit may comprise, for example, two half-wave rectifier circuits, two full-wave bridge rectifying circuits or one half-wave rectifier circuit and one full-wave bridge rectifying circuit.

According to the design of the pin in the LED tube lamp, there may be two pins in single end (the other end has no pin), two pins in corresponding ends of two ends, or four pins in corresponding ends of two ends. The designs of two pins in single end and two pins in corresponding ends of two ends are applicable to a signal rectifying circuit design of the rectifying circuit. The design of four pins in corresponding ends of two ends is applicable to a dual rectifying circuit design of the rectifying circuit, and the external driving signal can be received by two pins in only one end or any pin in each of two ends.

According to the design of the filtering circuit of the power supply module, there may be a single capacitor, or  $\pi$  filter circuit. The filtering circuit filters the high frequency component of the rectified signal for providing a DC signal with a low ripple voltage as the filtered signal. The filtering circuit also further comprises the LC filtering circuit having a high impedance for a specific frequency for conforming to current limitations in specific frequencies of the UL standard. Moreover, the filtering circuit according to some embodiments further comprises a filtering unit coupled between a rectifying circuit and the pin(s) for reducing the EMI resulted from the circuit(s) of the LED tube lamp. The LED tube lamp may omit the filtering circuit in the power supply module when the external driving signal is a DC signal.

According to the design of the LED lighting module in some embodiments, the LED lighting module may comprise the LED module and the driving circuit or only the LED module. The LED module may be connected with a voltage stabilization circuit in parallel for preventing the LED module from over voltage. The voltage stabilization circuit may be a voltage clamping circuit, such as Zener diode, DIAC and so on. When the rectifying circuit has a capacitive circuit, in some embodiments, two capacitors are respectively coupled between two corresponding pins in two end caps and so the two capacitors and the capacitive circuit as a voltage stabilization circuit perform a capacitive voltage divider.

58

If there are only the LED module in the LED lighting module and the external driving signal is a high frequency AC signal, a capacitive circuit (e.g., having at least one capacitor) is in at least one rectifying circuit and the capacitive circuit is connected in series with a half-wave rectifier circuit or a full-wave bridge rectifying circuit of the rectifying circuit and serves as a current modulation circuit (or a current regulator) to modulate or to regulate the current of the LED module due to that the capacitor equates a resistor for a high frequency signal. Thereby, even different ballasts provide high frequency signals with different voltage logic levels, the current of the LED module can be modulated into a defined current range for preventing overcurrent. In addition, an energy-releasing circuit is connected in parallel with the LED module. When the external driving signal is no longer supplied, the energy-releasing circuit releases the energy stored in the filtering circuit to lower a resonance effect of the filtering circuit and other circuits for restraining the flicker of the LED module. In some embodiments, if there are the LED module and the driving circuit in the LED lighting module, the driving circuit may be a buck converter, a boost converter, or a buck-boost converter. The driving circuit stabilizes the current of the LED module at a defined current value, and the defined current value may be modulated based on the external driving signal. For example, the defined current value may be increased with the increasing of the logic level of the external driving signal and reduced with the reducing of the logic level of the external driving signal. Moreover, a mode switching circuit may be added between the LED module and the driving circuit for switching the current from the filtering circuit directly or through the driving circuit inputting into the LED module.

A protection circuit may be additionally added to protect the LED module. The protection circuit detects the current and/or the voltage of the LED module to determine whether to enable corresponding over current and/or over voltage protection.

According to the design of the auxiliary power module of the power supply module, the energy storage unit may be a battery or a supercapacitor, connected in parallel with the LED module. The auxiliary power module is applicable to the LED lighting module having the driving circuit.

According to the design of the LED module of the power supply module, the LED module comprises plural strings of LEDs connected in parallel with each other, wherein each LED may have a single LED chip or plural LED chips emitting different spectrums. Each LEDs in different LED strings may be connected with each other to form a mesh connection.

In other words, the abovementioned features can be implemented in any combination to improve the LED tube lamp.

The above-mentioned exemplary features of the present invention can be accomplished in any combination to improve the LED tube lamp, and the above embodiments are described by way of example only. The present invention is not herein limited, and many variations are possible without departing from the spirit of the present invention and the scope as defined in the appended claims.

What is claimed is:

1. A light-emitting diode (LED) tube lamp, comprising: a lamp tube; two end caps, each having an external connection terminal, and each coupled to a respective end of the lamp tube, wherein the external connection terminals are configured to receive an external driving signal;



## US 9,841,174 B2

59

a rectifying circuit, coupled to the external connection terminals, for rectifying the external driving signal to produce a rectified signal;

a filtering circuit, coupled to the rectifying circuit, for filtering the rectified signal to produce a filtered signal;

a driving circuit, coupled to the filtering circuit, for converting the filtered signal into a driving signal;

an LED module, coupled to the driving circuit, for emitting light based on the driving signal; and

an installation detection module, configured to detect an installation state between the LED tube lamp and a lamp socket, wherein the installation detection module comprises:

- a first circuit, configured to generate a pulse signal, wherein the first circuit comprises a discharge path;
- a second circuit, coupled to the first circuit and configured to receive and output the pulse signal; and
- a third circuit, coupled to a power loop of the LED tube lamp and the second circuit and configured to determine whether to conduct the power loop according to the pulse signal,

wherein the pulse signal is fed back to the discharge path of the first circuit, and the discharge path is conducted when the pulse signal is pulled to a high level voltage, and

wherein the pulse signal is pulled to a low level voltage after the discharge path has been conducted for a predetermined time period.

2. The LED tube lamp according to claim 1, wherein the predetermined time period is a pulse-on period of the pulse signal.

3. The LED tube lamp according to claim 1, wherein the discharge path is cut off when the pulse signal is pulled to the low level voltage.

4. The LED tube lamp according to claim 1, wherein the third circuit comprises:

- a first resistor, having one end connected to a driving signal;
- a first capacitor, having one end connected to the other end of the first resistor, and the other end of the first capacitor being grounded;
- a Schmitt trigger, having an input end connected to the one end of the first capacitor, and an output end connected to the second circuit;
- a second resistor, having one end connected to the one end of the first capacitor;
- a transistor, having a base, a collector connected to the other end of the second resistor, and an emitter being grounded; and
- a third resistor, having one end connected to the base of the transistor, and the other end connected to the second circuit and the third circuit,

wherein the discharge path is formed by the transistor.

5. The LED tube lamp according to claim 1, wherein the installation detection module further comprises:

- a fourth circuit, configured to detect a sampling signal on the power loop so as to determine the installation state between the LED tube lamp and the lamp socket.

6. The LED tube lamp according to claim 5, wherein the fourth circuit further compares the sampling signal with a predefined signal, the fourth circuit outputs a high level signal when a signal level of the sampling signal is greater than or equal to the predefined signal and outputs a low level signal when the signal level of the sampling signal is smaller than the predefined signal.

60

7. The LED tube lamp according to claim 6, wherein the third circuit is conducted in response to the high level signal so as to cause the power loop to remain conductive.

8. The LED tube lamp according to claim 6, wherein the third circuit is cut off in response to the low level signal so as to cause the power loop to remain open.

9. The LED tube lamp according to claim 6, wherein the third circuit is cut off in response to the low level signal so as to reduce a current on the power loop less than 5 MIU (Measurement Indication Units).

10. A ballast by-pass light-emitting diode (LED) tube lamp, comprising:

- a lamp tube;
- two end caps, each having an external connection terminal, and each coupled to a respective end of the lamp tube, wherein the external connection terminals are configured to receive an external driving signal;
- an LED module, configured to emit light based on the external driving signal; and
- an installation detection module, coupled on a power loop of the LED tube lamp and configured to detect a transient current on the power loop and compare the transient current with a predefined signal,

wherein when a signal level of the transient current is smaller than the predefined signal, the installation detection module limits a current on the power loop less than 5 MIU by controlling a conduction state of the power loop.

11. The LED tube lamp according to claim 10, wherein the installation detection module comprises:

- a detection determining circuit, configured to detect the transient current, compare the transient current with the predefined signal, and output a high level signal or a low level signal according to a comparison result.

12. The LED tube lamp according to claim 11, wherein the installation detection module further comprises:

- a detection pulse generating module, configured to generate a pulse signal, wherein the detection determining circuit detects the transient current on the power loop during a pulse-on period of the pulse signal.

13. The LED tube lamp according to claim 12, wherein the detection pulse generating module comprises a discharge path, the pulse signal is fed back to the discharge path and the discharge path is conducted when the pulse signal is pulled to a high level voltage, and wherein the pulse signal is pulled to a low level voltage after the discharge path has been conducted for a predetermined time period.

14. The LED tube lamp according to claim 13, wherein the predetermined time period is the same as the pulse-on period of the pulse signal.

15. The LED tube lamp according to claim 13, wherein the discharge path is cut off when the pulse signal is pulled to the low level voltage.

16. The LED tube lamp according to claim 12, wherein the installation detection module further comprises:

- a switch circuit, coupled to the detection determining circuit and the detection pulse generating module and configured to maintain a conductive state during the pulse-on period of the pulse signal or when receiving the low level signal from the detection determining circuit.

17. The LED tube lamp according to claim 16, wherein the installation detection module further comprises:

- a detection result latching circuit, coupled to the detection determining circuit, the detection pulse generating module, and the switch circuit, wherein at least one of the pulse signal, the high level signal, and the low level

## US 9,841,174 B2

## 61

signal is provided to the switch circuit through the detection result latching circuit.

**18.** A detection method for a light-emitting device (LED) tube lamp for preventing a user from electric shock when the LED tube lamp is being installed on a lamp socket, the detection method comprising:

generating a pulse signal by a detection pulse generating module;

receiving the pulse signal by a switch circuit coupled on a power loop of the LED tube lamp, wherein the switch circuit is conducted during a pulse-on period of the pulse signal to cause the power loop to be conductive;

detecting a sampling signal on the power loop;

comparing the sampling signal with a predefined signal; and

limiting a current on the power loop less than 5 MIU when a signal level of the sampling signal is smaller than the predefined signal.

**19.** The detection method according to claim **18**, further comprising:

conducting the power loop when the signal level of the sampling signal is greater than or equal to the predefined signal.

**20.** The detection method according to claim **18**, wherein the detection pulse generating module comprises a discharge path, and the step of generating the pulse signal by the detection pulse generating module comprises:

pulling the pulse signal to a high level voltage when the detection pulse generating module receives a driving signal;

feeding the pulse signal back to the discharge path, so as to conduct the discharge path when the pulse signal is pulled to the high level voltage; and

pulling the pulse signal to a low level voltage after the discharge path has been conducted for a predetermined time period.

**21.** The detection method according to claim **20**, wherein the predetermined time period is the same as the pulse-on period of the pulse signal.

**22.** The detection method according to claim **20**, wherein the step of generating the pulse signal by the detection pulse generating module further comprises:

cutting off the discharge path when the pulse signal is pulled to the low level voltage.

**23.** A light-emitting diode (LED) tube lamp, comprising: a lamp tube;

two end caps, each having an external connection terminal, and each coupled to a respective end of the lamp tube, wherein the external connection terminals are configured to receive an external driving signal;

an LED module, configured to emit light based on the external driving signal; and

an installation detection module, coupled to a power loop of the LED tube lamp and configured to detect a sampling signal on the power loop and compare the sampling signal with a predefined signal,

wherein a leakage loop is formed between the external connection terminal on one of the end caps and a ground when the one of the end caps is inserted into a lamp socket but the other one is grounded by an object, and

wherein the installation detection module is activated by a driving voltage on the leakage loop.

**24.** The LED tube lamp according to claim **23**, wherein each end cap further has a dummy terminal for connecting to the lamp socket, and at least one dummy terminal is electrically isolated from the installation detection module.

## 62

**25.** The LED tube lamp according to claim **23**, wherein the driving voltage is generated based on the external driving signal when the leakage loop is formed.

**26.** A light-emitting diode (LED) tube lamp, comprising: a lamp tube;

two end caps, each having an external connection terminal, and each coupled to a respective end of the lamp tube, wherein the external connection terminals are configured to receive an external driving signal;

an LED module, configured to emit light based on the external driving signal; and

an installation detection module, coupled to a power loop of the LED tube lamp and configured to detect a sampling signal on the power loop and compare the sampling signal with a predefined signal,

wherein the installation detection module comprises:

a control module, configured to output a control signal for controlling a conduction state of the power loop and when a signal level of the sampling signal is smaller than the predefined signal, the control module limits a current on the power loop less than 5 MIU by controlling the conduction state,

wherein the control module generates the control signal having a first waveform during a detection stage and generates the control signal having a second waveform during an operating stage.

**27.** The LED tube lamp according to claim **26**, wherein the control module comprises:

a detection result latching circuit, coupled to a detection determining circuit, a detection pulse generating module, a switch circuit, wherein at least one of a pulse signal, a high level signal, and a low level signal is provided to the switch circuit through the detection result latching circuit.

**28.** A light-emitting diode (LED) tube lamp, comprising: a lamp tube;

two end caps, each having an external connection terminal, and each coupled to a respective end of the lamp tube, wherein the external connection terminals are configured to receive an external driving signal;

an LED module, configured to emit light based on the external driving signal; and

an installation detection module, coupled on a power loop of the LED tube lamp and configured to generate a pulse signal for controlling a conduction state of the power loop and detect a sampling signal on the power loop during a pulse-on time of the pulse signal,

wherein the installation detection module limits a current on the power loop to less than 5 MIU by setting the pulse-on time less than or equal to 1 millisecond.

**29.** The LED tube lamp according to claim **28**, wherein the installation detection module limits a current on the power loop to less than 5 MIU by setting the pulse-on time between 10 microseconds to 1 millisecond.

**30.** The LED tube lamp according to claim **28**, wherein the installation detection module limits a current on the power loop to less than 5 MIU by setting the pulse-on time between 1 microsecond to 100 microseconds.

**31.** The LED tube lamp according to claim **28**, wherein the installation detection module limits a current on the power loop to less than 5 MIU by setting the pulse-on time between 10 microseconds to 20 microseconds.

**32.** A light-emitting diode (LED) tube lamp, comprising: a lamp tube;

two end caps, each having an external connection terminal, and each coupled to a respective end of the lamp

## US 9,841,174 B2

**63**

tube, wherein the external connection terminals are  
configured to receive an external driving signal;  
an LED module, configured to emit light based on the  
external driving signal; and  
an installation detection module, coupled to a power loop 5  
of the LED tube lamp and configured to generate a  
plurality of pulse signals for controlling a conduction  
state of the power loop and detect a sampling signal on  
the power loop during a pulse-on time of each of the  
pulse signals, 10  
wherein a time interval between at least two consecutive  
pulse signals of the pulse signals is designed such that  
at least one of the two consecutive pulse signals occurs  
when the external driving signal is at non-zero level.

\* \* \* \* \*

15

**64**

UNITED STATES PATENT AND TRADEMARK OFFICE  
**CERTIFICATE OF CORRECTION**

PATENT NO. : 9,841,174 B2  
APPLICATION NO. : 15/426785  
DATED : December 12, 2017  
INVENTOR(S) : Xintong Liu, Aiming Xiong and Tao Jiang

Page 1 of 1

It is certified that error appears in the above-identified patent and that said Letters Patent is hereby corrected as shown below:

In the Specification

Column 42, Line 52, change 'any more' to ~~–anymore–~~.

Column 57, Line 42, change 'filers' to ~~–filters–~~.

In the Claims

Column 59, Line 38, Claim 4 change 'third' to ~~–first–~~.

Column 59, Line 41, Claim 4 change 'first capacitor' to ~~–capacitor–~~.

Column 59, Line 42, Claim 4 change 'first capacitor' to ~~–capacitor–~~.

Column 59, Line 45, Claim 4 change 'first capacitor' to ~~–capacitor–~~.

Column 59, Line 48, Claim 4 change 'first capacitor' to ~~–capacitor–~~.

Column 61, Line 3, Claim 18 change 'device' to ~~–diode–~~.

Signed and Sealed this  
Eleventh Day of December, 2018

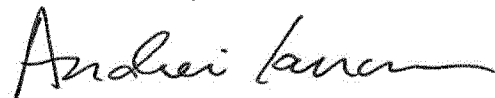

Andrei Iancu  
Director of the United States Patent and Trademark Office